

manuale d'installazione ed uso • installation and use manual • installations- und bedienungsanleitung
manuel d'installation et d'utilisation • manual de instalación y uso

MULTI SENTRY

MCT 10 - 12 - 15 - 20
MST 10 - 12 - 15 - 20



INTRODUCTION

Thank you for choosing our product.

Our company is specialised in designing, developing and manufacturing uninterruptible power supplies (UPS).

The UPS described in this manual is a high quality product which has been carefully designed and built in order to guarantee the highest levels of performance.

This manual contains detailed instructions for using and installing the product.

For information about using and getting the most out of your appliance, this manual must be stored with care in the vicinity of the UPS and CONSULTED BEFORE OPERATING ON IT.

NOTE: Some images contained within this document are for indication purposes only and therefore may not identically match the products in use.

ENVIRONMENTAL PROTECTION

During the development of its products, the company uses extensive resources with regards to all environmental aspects. All our products pursue the objective defined in the environmental management system developed by the company in compliance with standards in force.

No hazardous materials such as CFC, HCFC or asbestos are used in this product.

When evaluating packaging, the choice of material has been made favouring recyclable materials.

For correct disposal, please separate and identify the type of material of which the packaging is made in the table below. Dispose of all material in compliance with standards in force in the country in which the product is used.

DESCRIPTION	MATERIAL
Pallet	Heat-treated pine
Packaging corner	Stratocell/cardboard
Box	Cardboard
Adhesive pad	Stratocell
Protective bag	HD Polyethylene

DISPOSING OF THE PRODUCT

The UPS contains internal material that (in case of dismiss / disposal) are considered TOXIC and HAZARDOUS WASTE, such as electronic circuit boards and batteries. Treat these materials according to the laws applicable referring to qualified service personnel. Their proper disposal contributes to respect the environment and human health.

© The reproduction of any part of this manual, in whole or in part, is forbidden without the prior consent of the manufacturer. In order to make improvements, the manufacturer reserves the right to modify the product described at any moment and without notice.

CONTENTS

OVERVIEW	5
<i>MULTI SENTRY</i>	5
<i>MCT VIEWS</i>	6
<i>MST VIEWS</i>	7
<i>VIEW OF THE MCT CONNECTIONS</i>	8
<i>VIEW OF THE MST CONNECTIONS</i>	9
<i>VIEW OF THE CONTROL PANEL</i>	10
<i>BATTERY BOX (OPTIONAL)</i>	11
<i>SEPARATE BYPASS INPUT (OPTIONAL)</i>	12
<i>ADDITIONAL INTERNAL BATTERY CHARGERS</i>	12
<i>INTERNAL TRANSFORMER (OPTIONAL)</i>	13
<i>208 V VERSION (OPTIONAL)</i>	14
<i>EXTERNAL PROTECTIVE DEVICES</i>	14
<i>CROSS SECTION OF THE CABLES</i>	15
<i>CONNECTIONS</i>	15
<i>INTERNAL TRANSFORMERS VIEW</i>	15
<i>TECHNICAL DATA</i>	16
<i>REDUCING THE LOAD (TO 115V AND 110V)</i>	17
<i>CONNECTIONS</i>	18
INSTALLATION	19
<i>STORING THE UPS AND THE BATTERY BOX</i>	19
PREPARING FOR INSTALLATION	19
<i>PRELIMINARY INFORMATION</i>	19
<i>ELECTROMAGNETIC COMPATIBILITY</i>	20
<i>INSTALLATION ENVIRONMENT</i>	20
<i>INTERNAL BATTERIES</i>	21
<i>REMOVING THE UPS AND THE BATTERY BOX FROM THE PALLET</i>	22
<i>PRELIMINARY CHECK OF CONTENTS</i>	24
<i>INSTALLING THE UPS AND THE BATTERY BOX</i>	24
<i>STEPS TO BE TAKEN TO GAIN ACCESS TO THE TERMINALS OF THE UPS / BATTERY BOX</i>	24
ELECTRICAL CONNECTIONS	25
<i>WIRING DIAGRAMS FOR CONNECTING TO THE ELECTRICAL SYSTEM</i>	25
<i>INTERNAL PROTECTIVE DEVICES OF THE UPS</i>	28
<i>EXTERNAL PROTECTIVE DEVICES</i>	29
<i>CROSS SECTION OF THE CABLES</i>	30
<i>CONNECTIONS</i>	30
<i>CONNECTIONS OF THE MODEL WITH SEPARATE BYPASS</i>	31
R.E.P.O.	32
EXTERNAL SYNC	32

CONNECTING THE REMOTE MAINTENANCE BYPASS	33
CONNECTING THE BATTERY BOX TO THE UPS	35
MULTIPLE EXPANSIONS	36
SETTING THE RATED BATTERY CAPACITY – SOFTWARE CONFIGURATION	36
EXTERNAL TEMPERATURE PROBE	37
REMOTE PANEL (OPTIONAL)	37
USE	38
<hr/>	
DESCRIPTION	38
PRELIMINARY OPERATIONS	39
POWERING ON FOR THE FIRST TIME	40
POWERING ON FROM THE MAINS	41
POWERING ON FROM THE BATTERY	41
POWERING OFF THE UPS	41
GRAPHIC DISPLAY	42
DISPLAY MENUS	44
OPERATING MODES	45
MAINTENANCE BYPASS (SWMB)	45
REDUNDANT AUXILIARY POWER SUPPLY FOR AUTOMATIC BYPASS	46
AUXILIARY SOCKETS (OPTIONAL)	46
ENERGYSHARE	46
AUX OUTPUT	46
POWER WALK-IN	46
REDUCING THE LOAD (TO 200V AND 208V)	47
CONFIGURING THE UPS	47
COMMUNICATION PORTS	50
RS232 AND USB CONNECTORS	50
COMMUNICATION SLOTS	50
AS400 PORT	51
BUZZER	52
SOFTWARE	53
MONITORING AND CONTROL SOFTWARE	53
CONFIGURATION SOFTWARE	53
TROUBLESHOOTING GUIDE	54
<hr/>	
STATUS / ALARM CODES	58
TECHNICAL DATA	62
<hr/>	

OVERVIEW

MULTI SENTRY

The UPS units of the **Multi Sentry** 10 – 12 – 15 – 20 kVA range (VFI-SS-111 type) have been designed using the latest technology available today so as to guarantee users maximum performance. The use of the new control PCBs based on multiprocessor architecture (DSP + μ P inside) together with high frequency IGBT technology offers excellent performance both in the input stage (absorbed current harmonic distortion \leq 3%) and in output (output voltage distortion \leq 1%).

Thanks to these and many other features plus the easy-to-use design, the **Multi Sentry** represents a new reference standard in the three-phase UPS sector.

Depending on user requirements, there are two different versions available:

MCT

The **Multi Sentry MCT version** stands out by its compact size and new, modern design. These features make it suitable for any environment.

MST

The **Multi Sentry MST version**, offers longer autonomy than the **MCT** version, thanks to the possibility to double the number of batteries inside the cabinet.

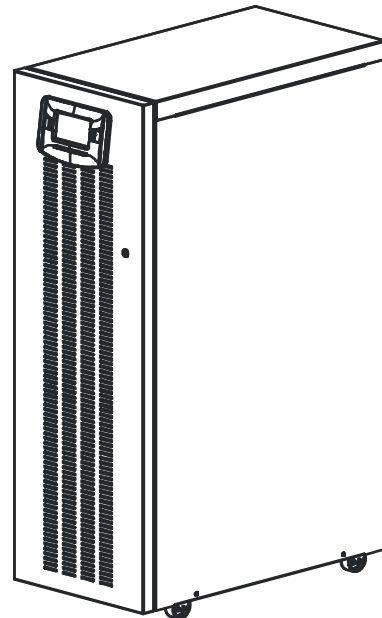
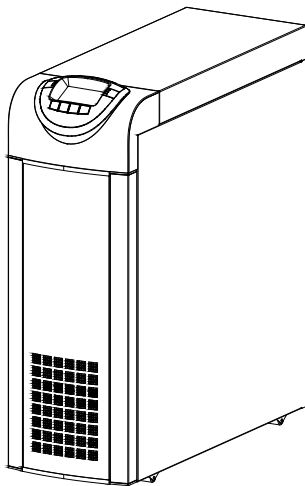

		10 kVA	12 kVA	15 kVA	20 kVA
Nominal power		10000 VA 9000 W	12000 VA 10800 W	15000 VA 13500 W	20000 VA 18000 W
Output power factor		0.9	0.9	0.9	0.9
Weight (with batteries)	MCT	185 Kg	187 Kg	195 Kg	200 Kg
	MST	315 Kg	320 Kg	325 Kg	330 Kg
W x D x H	MCT	320 x 840 x 930 mm			
	MST	440 x 850 x 1320 mm			
Accessories		Battery cabinets – Communication boards – Remote mimic panel			

MCT VIEWS

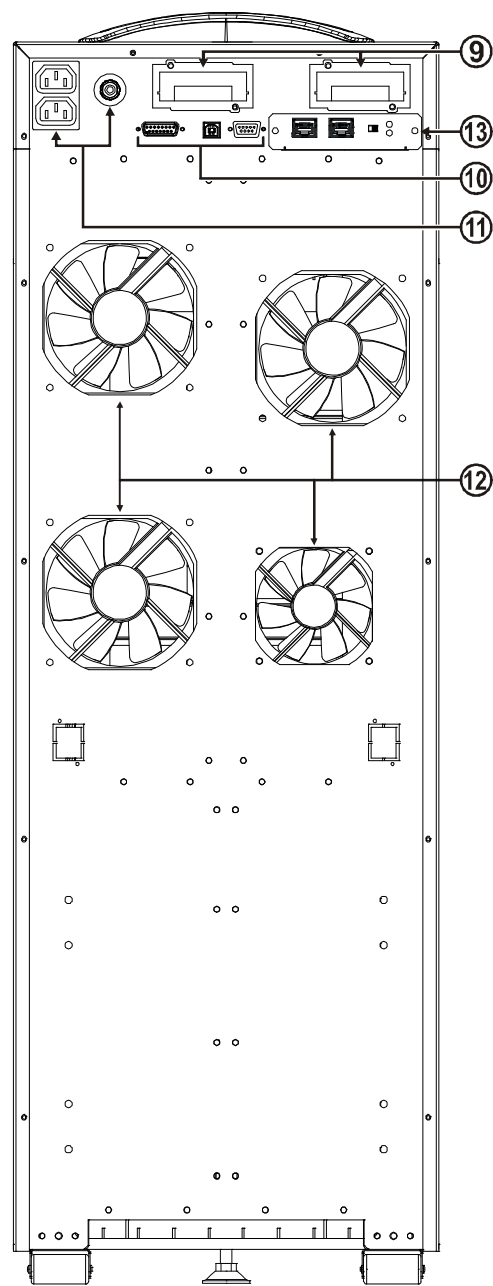
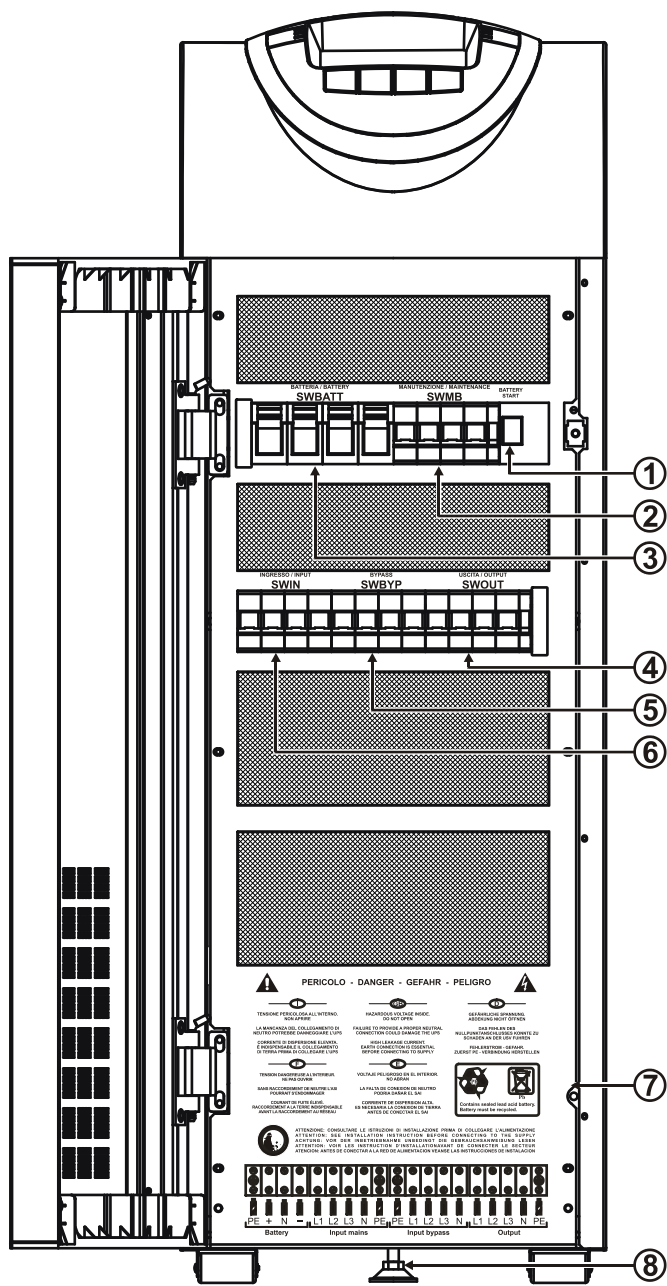

- | | |
|---|---|
| <ul style="list-style-type: none"> ① Battery start button (COLD START) ② Manual bypass switch ③ Battery fuse holder isolator ④ Output switch ⑤ Separate bypass switch (optional) ⑥ Input switch ⑦ Terminal cover panel | <ul style="list-style-type: none"> ⑧ Brake rod ⑨ Slots for accessory communication cards ⑩ Communication ports (AS400, USB, RS232) ⑪ EnergyShare sockets (10A max. total on the two sockets) and relative protection ⑫ Ventilation fans ⑬ Parallel PCB (optional) |
|---|---|

MST VIEWS

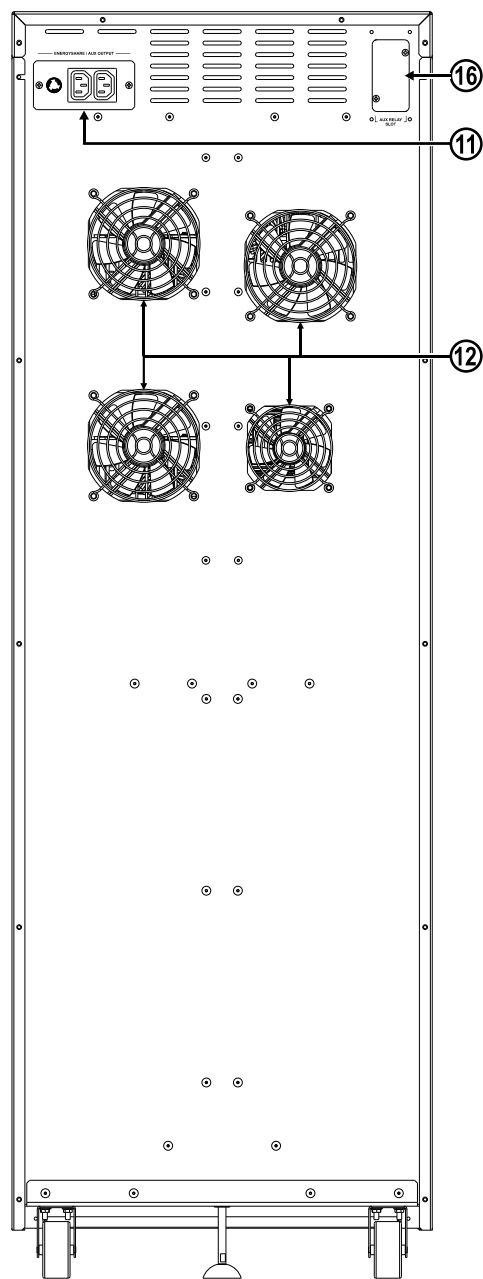
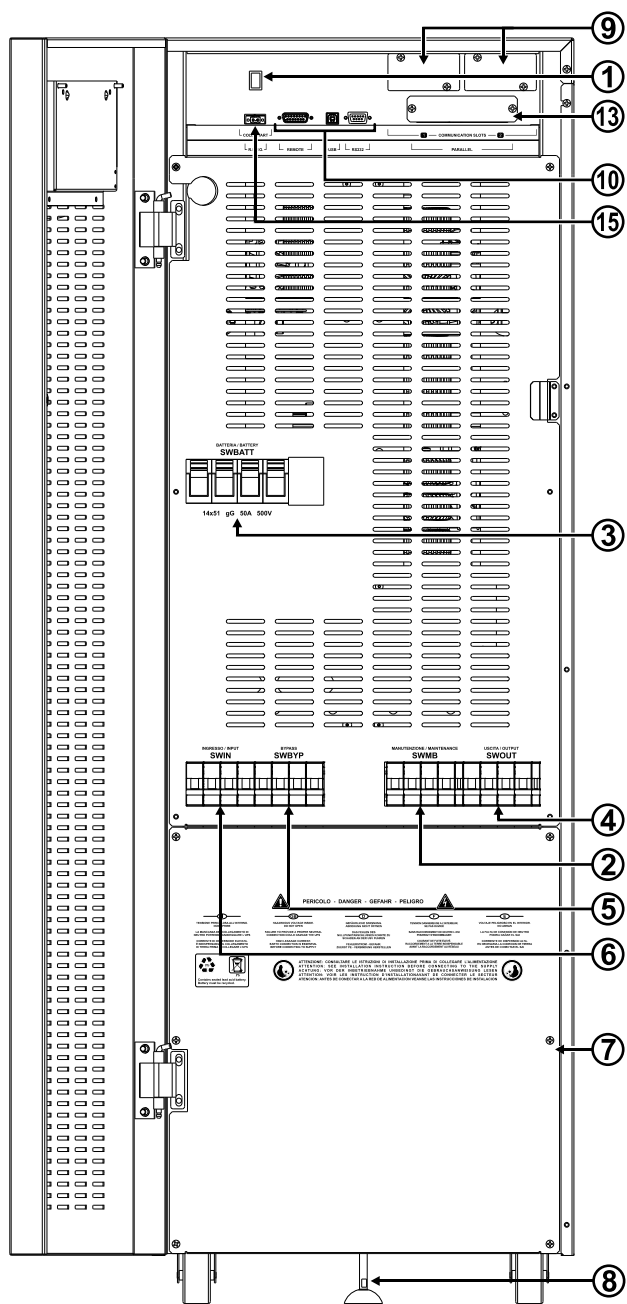

- ① Battery start button (COLD START)
- ② Manual bypass switch
- ③ Battery fuse holder isolator
- ④ Output switch
- ⑤ Separate bypass switch (optional)
- ⑥ Input switch
- ⑦ Terminal cover panel
- ⑧ Brake rod
- ⑨ Slots for accessory communication cards
- ⑩ Communication ports (AS400, USB, RS232)
- ⑪ EnergyShare / Aux Output sockets (10A max.) and relative protection (optional)
- ⑫ Ventilation fans
- ⑬ Parallel PCB (optional)
- ⑭ Remote Emergency Power Off (R.E.P.O.)
- ⑮ Slot for power relay board

VIEW OF THE MCT CONNECTIONS

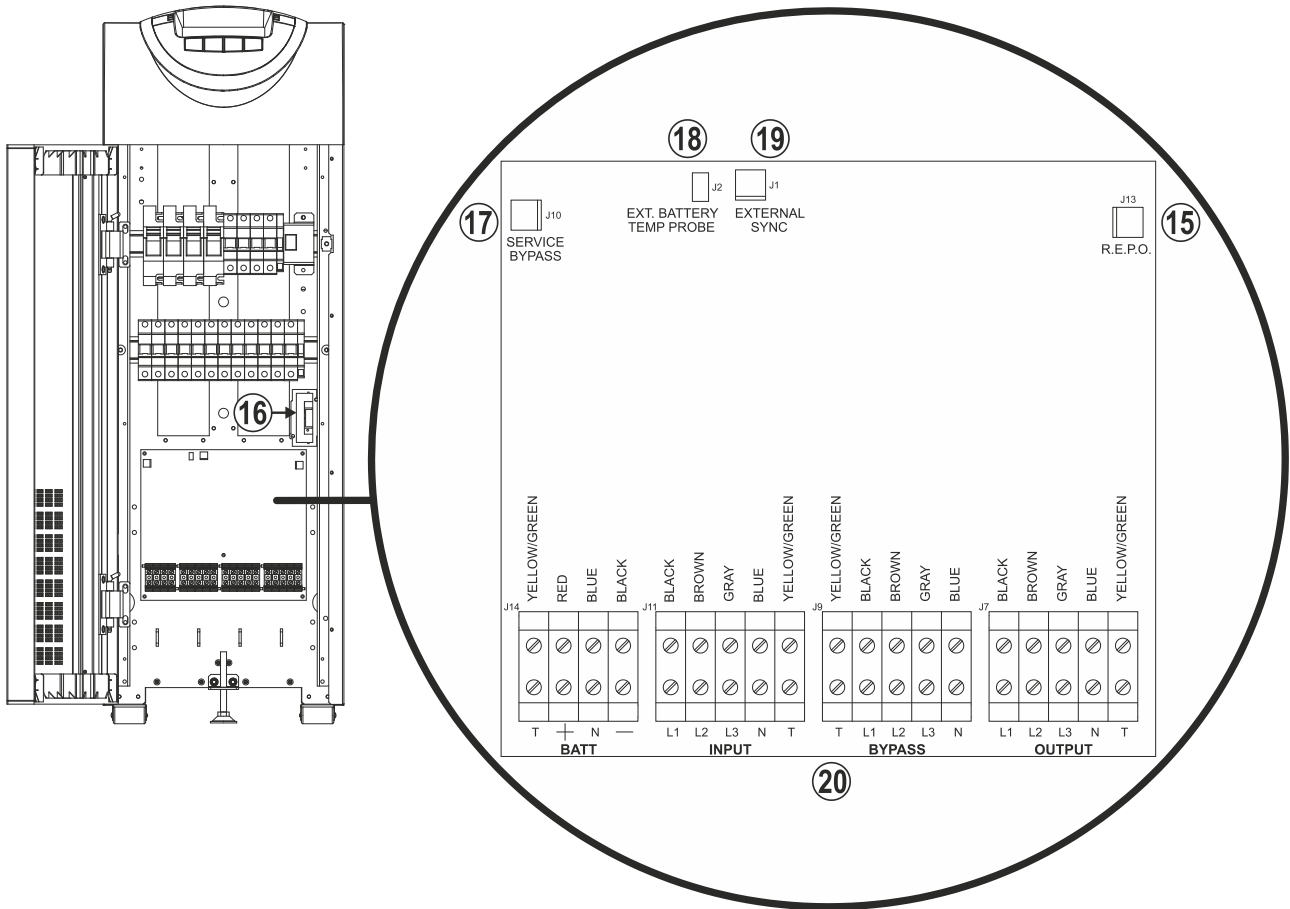

- ⑮ Connection for the R.E.P.O command (Remote Emergency Power Off)
- ⑯ Slot for power relay board
- ⑰ Connection for remote maintenance bypass command
- ⑱ Connection for external Battery Box temperature probe
- ⑲ Connection for external synchronization signal
- ⑳ Power connections: BATTERY, INPUT, SEPARATE BYPASS (optional), OUTPUT

VIEW OF THE MST CONNECTIONS

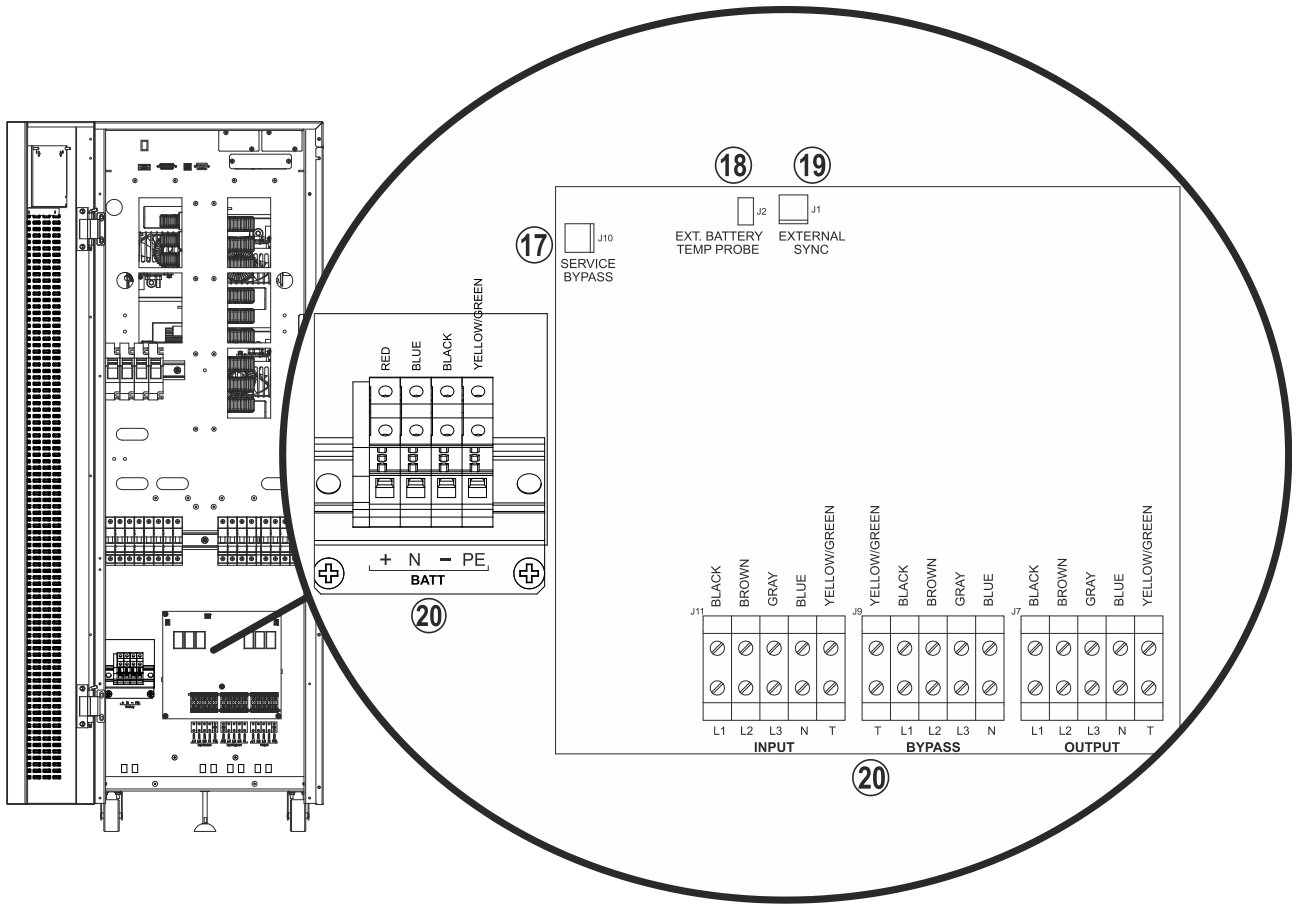

- ①⑦ Connection for remote maintenance bypass command
- ①⑧ Connection for external Battery Box temperature probe
- ①⑨ Connection for external synchronization signal
- ②⑩ Power connections: BATTERY, INPUT, SEPARATE BYPASS (optional), OUTPUT

VIEW OF THE CONTROL PANEL

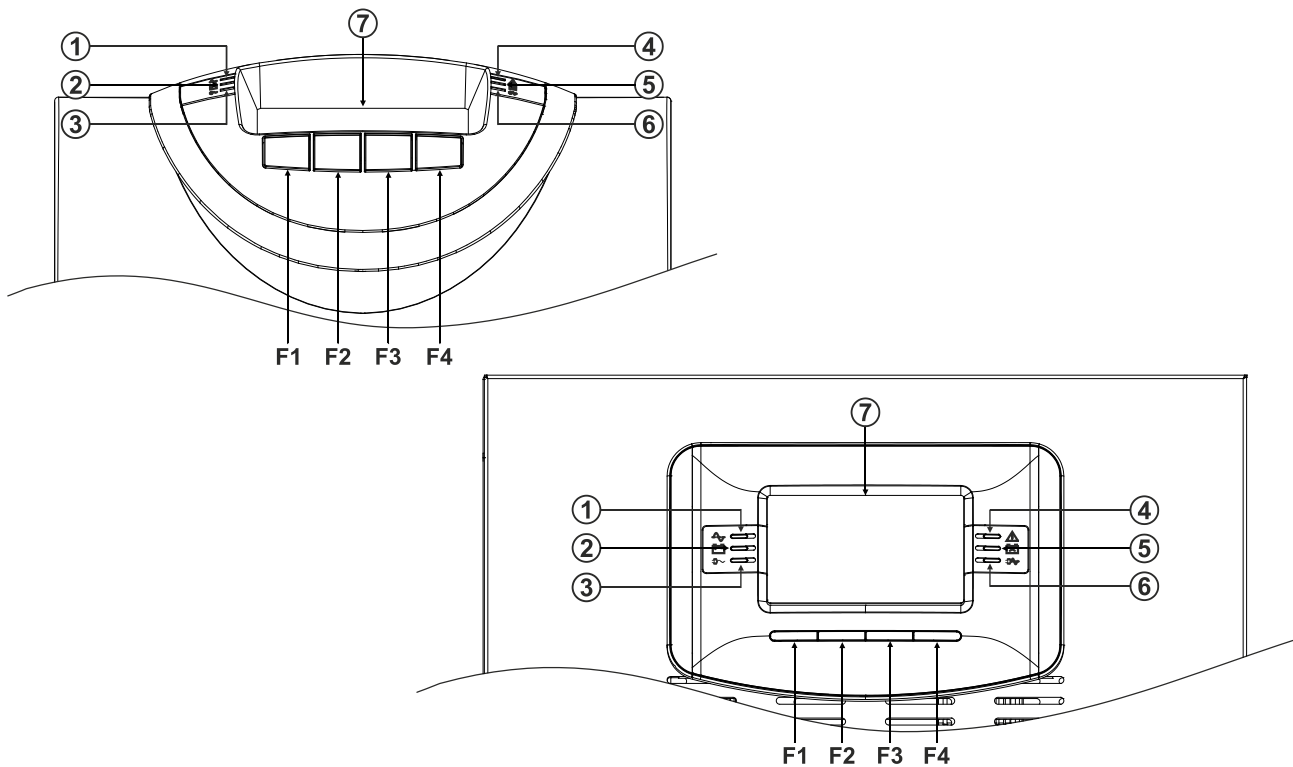

Mains operation LED

- ①
- *On steady*: mains operation with good bypass line and synchronised inverter
 - *Flashing*: mains operation with bad or disabled bypass line and/or non-synchronised inverter
 - *Flashing in standby*: programmed restart function active and mains present

Battery operation LED

- ②
- *On steady*: battery operation
 - *Flashing*: battery operation with early low battery or imminent shutdown warning
 - *Flashing in standby*: programmed restart function active and mains absent

Load on bypass LED

- ③
- *On steady*: load powered from bypass line

Standby/alarm LED

- ④
- *On steady*: replace batteries
 - *Flashing*: batteries overloaded alarm

Replace batteries LED

- ⑤
- *On steady*: replace batteries
 - *Flashing*: batteries overloaded alarm

ECO mode LED

- ⑥
- *On steady*: ECO mode configuration active

⑦ Graphic display

F1, F2, F3, F4 = FUNCTION KEYS. Each key's task can be found on the lower part of the display and varies according to menu.

BATTERY BOX (OPTIONAL)

THE BATTERY BOX IS AN OPTIONAL ACCESSORY.

The Battery Box contains batteries that increase the operating time of the UPS during prolonged black-outs. The number of batteries contained in it will vary according to the type of UPS to which the Battery Box is to be installed. The utmost attention must be paid to ensure that the battery voltage of the Battery Box corresponds to that supported by the UPS.

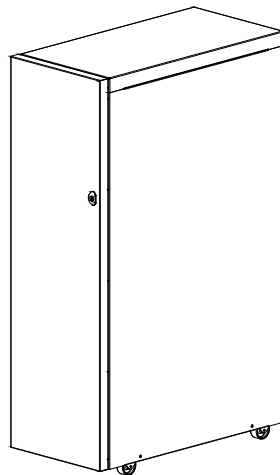

Additional Battery Boxes may be connected in a chain to obtain the desired autonomy time during a power failure. This series of Battery Box contains two separate strings of batteries, one with a positive voltage and the other with a negative voltage with respect to the neutral terminal (N). The basic diagram for the Battery Box is shown here below.

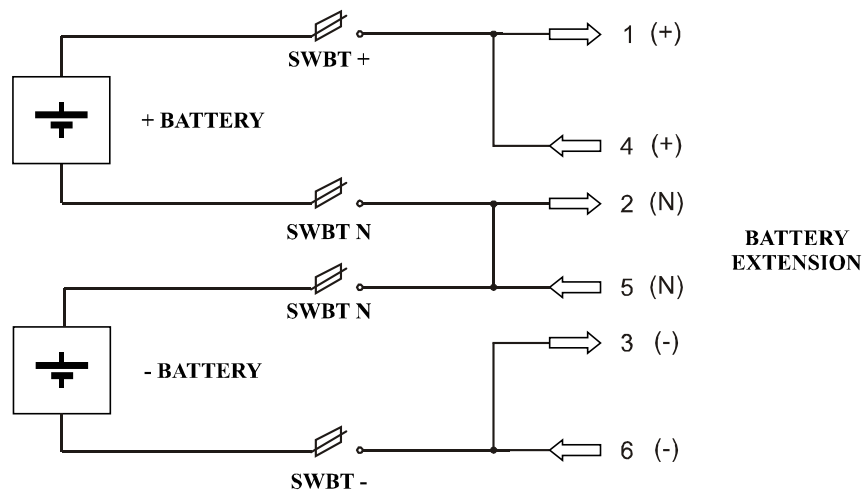

	BBX 1320 480V BB NP T4 3F	BBX 1320 480V BB NP T2 3F	BBX 1320 480V BB NP T5 3F
Rated voltage	240 + 240 Vdc	240 + 240 Vdc	240 + 240 Vdc
Weight	300 Kg	390 Kg	400 Kg
W x D x H	400 x 815 x 1320 mm		

SEPARATE BYPASS INPUT (OPTIONAL)

THE **DI** (OPTIONAL) VERSION OF THE UPS SERIES HAS SEPARATE BYPASS AND INPUT LINES.

The UPS series with separate Bypass ensures a separate connection between the input and bypass lines. The UPS output is synchronised with the bypass line so as to safeguard against incorrect voltage changeovers in the alternate phases, in the event of automatic bypass or closing of the maintenance switch (SWMB).

ADDITIONAL INTERNAL BATTERY CHARGERS

THE **ER** (OPTIONAL) VERSION OF THE UPS SERIES DIFFERS FROM THE STANDARD VERSION IN THAT SOME ADDITIONAL BATTERY CHARGERS ARE USED INSTEAD OF THE BATTERIES.

This series of UPS must be used together with an external Battery Box and is suitable for applications requiring long back-up times.

NOTE: A separate bypass line is supplied on this UPS version.

The additional internal battery charger cards are powered directly on mains power and have pseudo-sinusoidal wave form absorption.



If the input switch is closed but the I/O switch is open (UPS switched off) the battery chargers operate independently. Open the input switch (SWIN) to totally shutdown the UPS and the additional battery chargers.

ER Version	10 kVA	12 kVA	15 kVA	20 kVA
Nominal voltage		240 + 240 Vdc		
Current in addition to that supplied by the internal battery charger		6A@240Vdc		

INTERNAL TRANSFORMER (OPTIONAL)

THE **OT** (OPTIONAL) VERSION OF THE UPS SERIES DIFFERS FROM THE STANDARD VERSION IN THAT IT USES AN ISOLATION TRANSFORMER INSTEAD OF THE BATTERIES.

This series of UPS uses an isolation transformer connected to the UPS output terminals.

NOTE: A separate bypass line is supplied on this UPS version.

The transformer is connected to the UPS output terminals, so the values displayed are those of the quantities measured upstream of the transformer.



The presence of the transformer inside the UPS modifies the system neutral arrangements.

The installation of a remote maintenance bypass parallel to the UPS is incompatible with inclusion of the transformer. In any event, if the remote maintenance bypass is inserted, make sure, at the time the remote bypass switch is closed, that the UPS is isolated from the system by opening the input and/or output switches.

*UPS version with internal transformer is supplied with neutral on secondary circuit **not** connected to earth. It shall be bind to earth according with neutral arrangement on the site.*



ATTENTION:

Manual By-pass change over operation does not insulate the transformer inside which continue to supply the load; the personnel operating inside the UPS should be aware that under these conditions some part are subjected to dangerous voltages

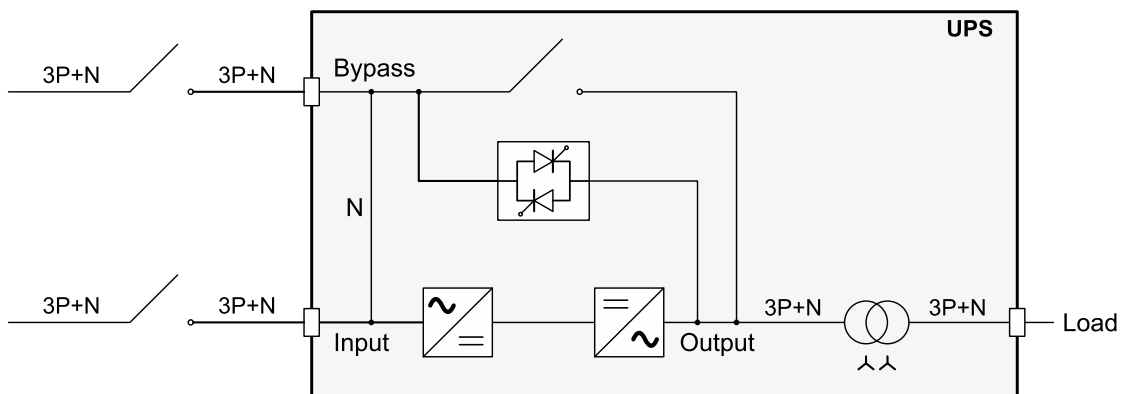
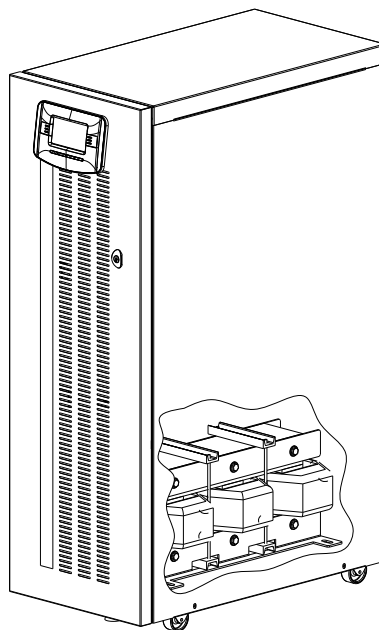

208 V VERSION (OPTIONAL)

THE **208 V VERSION (OPTIONAL)** IN THE UPS SERIES DIFFERS FROM THE STANDARD VERSION AS REGARDS THE INPUT AND OUTPUT VOLTAGE. THIS LEADS TO A SERIES OF PARAMETERS THAT DIFFER FROM THE STANDARD VERSION, LISTED BELOW.



CAUTION: *The data contained in this paragraph applies to the 208 V Version only.*

EXTERNAL PROTECTIVE DEVICES

MAGNETOTHERMAL

As explained previously, the UPS has protection devices for output faults as well as for internal faults. In order to set up the power line, install a magnetothermal switch upstream from the UPS with intervention curve B or C. Please follow the indications in the table below:

UPS mod.	Automatic external protective devices	
	Mains input	
10 kVA	80A	
12 kVA	80A	
15 kVA	125A	
20 kVA	125A	



If the protective device upstream from the UPS interrupts the neutral wire, it must also interrupt all the phase wires at the same time (four-pole switch).

Output protections (recommended values for discrimination)	
Normal fuses (GI)	In (Nominal current)/7
Normal switches (C curve)	In (Nominal current)/7
Ultra-fast fuses (GF)	In (Nominal current)/2

DIFFERENTIAL

**THE UPS INPUT NEUTRAL IS CONNECTED TO THE UPS OUTPUT NEUTRAL
THE DISTRIBUTION SYSTEM THAT POWERS THE UPS IS NOT MODIFIED BY THE UPS**



The neutral condition is only modified if an isolation transformer is present or when the UPS works with a neutral isolated upstream.

Make sure that the equipment is connected correctly to the input neutral because as damage may be caused to the UPS.

During operation with the mains supply present, a differential switch (RCD) at the input to the UPS will activate should a fault occur on the output side as the output circuit is not isolated from the input circuit.

In any case, other differential switches may still be installed on the output, preferably in coordination with those present at the input.

The differential switch located upstream must have the following characteristics:

- Differential current adjusted to the sum of UPS + Load; we recommend a suitable margin be kept to prevent unwanted activation (100mA min. - 300mA recommended)
- Type B
- Delay of at least 0.1s

CROSS SECTION OF THE CABLES

We recommend the INPUT/OUTPUT and BATTERY cables be passed under the UPS.
To determine the minimum cross section of the input and output cables, see the table below:

Cross section of cables (mm ²)*									
kVA	INPUT mains / separate bypass (optional)			OUTPUT			BATTERY** (optional)		
	PE	L1/L2/L3	N	PE	L1/L2/L3	N	PE	+/-	N
10	10	6	10	10	6	10	4	4	4
12	10	6	10	10	6	10	6	6	6
15	16	10	16	16	10	16	6	6	6
20	25	16	25	25	16	25	10	10	10

* The cross sections indicated in the table refer to a maximum length of 10 metres

** The maximum length of the cables for connecting the Battery Box (optional) is 3 metres

Note: the maximum cross section of the cables that may be inserted in the terminal board is:

- 25 mm² for trailing cables
- 35 mm² for rigid cables

CONNECTIONS



The first wire to be connected is the protective earth wire, which is to be inserted in the terminal marked PE. During operation the UPS must be connected to the earthing system



THE INPUT NEUTRAL MUST ALWAYS BE CONNECTED

Note 1: The protection conductor (earth cable) connection must be carried out through eyelet terminal stud M6

Note 2: the connections to the BATTERY module must only be made if the Battery Box (optional) is present.

INTERNAL TRANSFORMERS VIEW

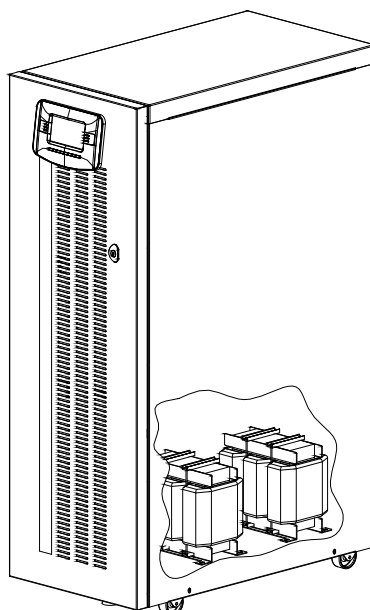

TECHNICAL DATA

UPS Models	10 kVA	12 kVA	15 kVA	20 kVA
Input stage				
Rated voltage	208-220-228 Vac Three-phase with neutral (4 wires)			
Rated frequency	50-60Hz			
Accepted tolerance for input voltage without activation of battery (for 220Vac)	±20% @ 100% load -40% +20% @50% load			
Accepted tolerance for input frequency without activation of battery (for 50/60Hz)	±20% 40-72Hz			
Technology	IGBT high frequency with PFC control, independent digital average current mode on each input phase			
Input current harmonic distortion	THDi ≤ 3 % ⁽⁷⁾			
Input power factor	≥ 0.99%			
Power Walk-in	Programmable from 1 to 125 sec. in steps of 1 sec.			
Inrush current	< 10 In			
Output stage				
Rated voltage ⁽¹⁾	208/220/228 Vac Three-phase with neutral (4 wires)			
Rated frequency ⁽²⁾	50/60Hz			
Rated apparent output power	10kVA	12kVA	15kVA	20kVA
Rated active output power	9kW	10.8kW	13.5kW	18kW
Output power factor	0,9			
Short circuit current	1,5x In for t>500ms			
Precision of output voltage (with respect to output voltage 220Vac)	± 1%			
Static stability ⁽³⁾	± 2%			
Dynamic stability	± 3% resistive load ⁽⁴⁾			
Crest factor allowed at rated load	3:1			
Precision of frequency in free running mode	0.01%			
Inverter overload (Vin>190V AC)	103% Infinite, 110% 10 min, 125% 1 min			
Bypass Overload	110% Infinite, 125% 60 minutes, 150% 10 minutes			
Technology	IGBT high frequency with multiprocessor digital control (DSP+μP), voltage/current based on signal processing methods with feed forward			
Battery charger stage				
Rated voltage	±240Vdc			
Maximum recharging current ⁽⁵⁾	6A			
Battery charger algorithm	Two levels with temperature compensation			
Technology	Analogue switching current mode under the control of the μP (PWM regulation of charging voltage and current)			
Tolerance of input voltage for recharging at maximum current	190-264Vac			

UPS Models	10 kVA	12 kVA	15 kVA	20 kVA
------------	--------	--------	--------	--------

Dimensions and weight

W x D x H	440 x 850 x 1320 mm			
Weight	205 Kg	210 Kg	247 Kg	252 Kg

Miscellaneous

Noise	≤48dB(A)		≤52dB(A)	
Color	RAL 7016			
Ambient temperature ⁽⁶⁾	0 – 40 °C			

- (1) To maintain the output voltage within the range of precision indicated, it may have to be recalibrated after a long period of operation
- (2) If the mains frequency is within $\pm 5\%$ of the selected value, the UPS is synchronized with the mains. If the frequency is outside the tolerance limits or running on the battery, the frequency is the value selected $\pm 0.1\%$
- (3) Mains/Battery @ load 0% -100%
- (4) @ Mains / battery / mains @ resistive load 0% / 100% / 0%
- (5) The recharging current is regulated automatically according to the capacity of the battery installed
- (6) 20 – 25 °C for maximum battery life
- (7) @ 100% load & THDv $\leq 1\%$

Battery Box	BBX 1320 480V BB NP T4 3F	BBX 1320 480V BB NP T2 3F	BBX 1320 480V BB NP T5 3F
-------------	------------------------------	------------------------------	------------------------------

Battery

Rated voltage per branch	240 Vdc		
No. batteries / V / Ah	80 / 12 / 9	120 / 12 / 7	120 / 12 / 9

Miscellaneous

Ambient temperature ⁽¹⁾	0 – 40 °C		
Humidity	<95% non-condensing		
Protective devices	Overcurrent – Short circuit		
W x D x H	400 x 815 x 1320 mm		
Weight	300 Kg	390 Kg	400 Kg

- (1) 20 – 25 °C for maximum battery life

REDUCING THE LOAD (TO 115V AND 110V)

If the output voltage is set to 115V and 110V (see “Configuring the UPS” paragraph), the maximum power output of the UPS is reduced with respect to its rated value.

- 228 (Ph-Ph) ; 132 (Ph-N) = NO power output downgrading
- 220 (Ph-Ph) ; 127 (Ph-N) = NO power output downgrading
- 208 (Ph-Ph) ; 120 (Ph-N) = NO power output downgrading
- 199 (Ph-Ph) ; 115 (Ph-N) = 5% power output downgrading
- 190 (Ph-Ph) ; 110 (Ph-N) = 10% power output downgrading

CONNECTIONS



The very first connection to be carried out is that of the protection conductor (earth cable).
The UPS must not operate without being connected to an earthing system



THE INPUT NEUTRAL MUST ALWAYS BE CONNECTED

Connect the input and output cables to the terminal board as shown in the figure below:

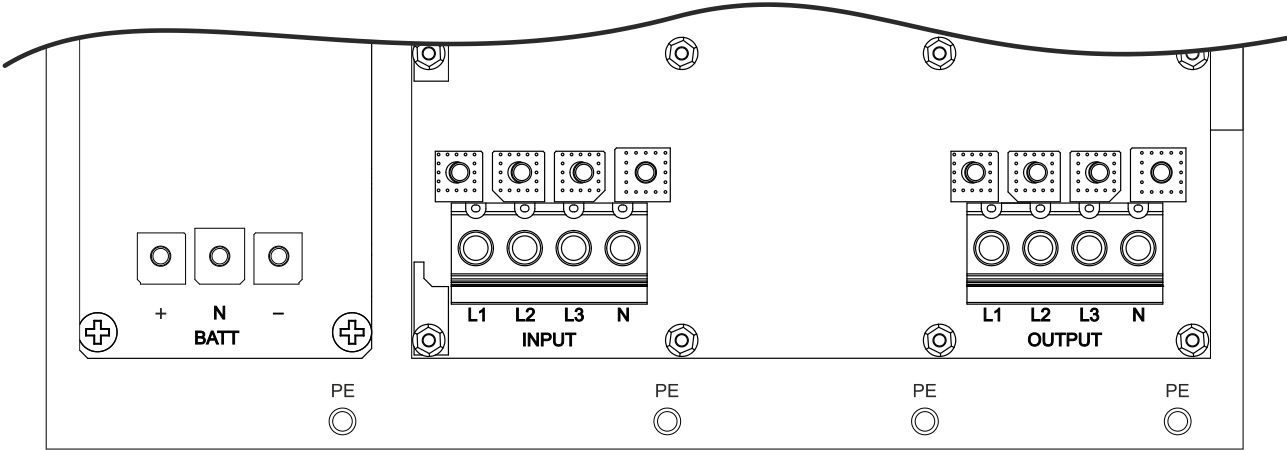

Note: the connections to the BATTERY module must only be made if the Battery Box (optional) is present.

INSTALLATION



ALL THE OPERATIONS DESCRIBED IN THIS SECTION ARE TO BE PERFORMED EXCLUSIVELY BY QUALIFIED STAFF.



The company declines all liability for damage caused by incorrect connections or operations not described in this manual.

STORING THE UPS AND THE BATTERY BOX

The storage room must respect the following conditions:

Temperature: $0^{\circ}\pm 40^{\circ}\text{C}$ ($32^{\circ}\pm 104^{\circ}\text{F}$)

Relative humidity: max. 95%

PREPARING FOR INSTALLATION

PRELIMINARY INFORMATION

UPS models		10 kVA	12 kVA	15 kVA	20 kVA
Rated power		10000 VA	12000 VA	15000 VA	20000 VA
Working temperature		0 ÷ 40 °C			
Max. relative humidity during operation		90 % (non-condensing)			
Max. height of installation		1000 m at rated power (-1% Power for every 100 m above 1000 m) max 4000 m			
W x D x H	MCT	320 x 840 x 930 mm			
	MST	440 x 850 x 1320 mm			
Weight (w/ batteries)	MCT	185 Kg	187 Kg	195 Kg	200 Kg
	MST	315 Kg	320 Kg	325 Kg	330 Kg
Power dissipated at rated resistive load (pf=0.9) and with battery as buffer *		0.63 kW 540 kcal/h 2150 B.T.U./h	0.75 kW 645 kcal/h 2560 B.T.U./h	0.86 kW 740 kcal/h 2940 B.T.U./h	1.15 kW 990 kcal/h 3930 B.T.U./h
Power dissipated at rated distortion load (pf=0.7) and with battery charged *		0.49 kW 420 kcal/h 1670 B.T.U./h	0.58 kW 500 kcal/h 1980 B.T.U./h	0.67 kW 580 kcal/h 2290 B.T.U./h	0.90 kW 775 kcal/h 3070 B.T.U./h
Flow rate of fans for removing heat from installation room **		340 mc/h	400 mc/h	460 mc/h	615 mc/h
Current leak to earth ***		< 5 mA			
Isolation protection		IP20			
Cable input		From bottom / on rear			

* $3.97 \text{ B.T.U./h} = 1 \text{ kcal/h}$

** To calculate the air flow rate, the following formula may be used: $Q [\text{m}^3/\text{h}] = 3.1 \times P_{\text{diss}} [\text{Kcal/h}] / (t_a - t_e) [^{\circ}\text{C}]$
 P_{diss} is the power expressed in Kcal/h dissipated by all the devices installed in the installation environment.
 t_a = ambient temperature, t_e =outside temperature. To take leaks into account, the value obtained should be increased by 10%.

The table shows an example of a flow rate with $(t_a - t_e)=5^{\circ}\text{C}$ and a rated resistive load (pf=0.9).

(Note: This formula is applicable if $t_a > t_e$, only; if not the UPS installation requires an air-conditioning system).

*** The leakage current of the load is to be added to that of the UPS on the earth wire.

ELECTROMAGNETIC COMPATIBILITY

This UPS product conforms to the current electromagnetic compatibility (EMC) regulations (C2 class). It may cause radio interference in the home environment. The user may have to adopt supplementary measures.

This product is for professional use in industrial and commercial environments. Connections to USB and RS232 connectors must be made with the cables provided, or at least with shielded cables less than 3 metres long.

INSTALLATION ENVIRONMENT

When choosing the site in which to install the UPS and the Battery Box, the following points should be taken into consideration:

- Avoid dusty environments
- Check that the floor is level and capable of withstanding the weight of the UPS and the Battery Box
- Avoid cramped environments that could impede the normal maintenance activities
- The relative humidity should not exceed 90%, non-condensing
- Check that the ambient temperature, with the UPS running, remains between 0 and 40°C



The UPS may be operated with an ambient temperature of between 0 and 40°C. The recommended working temperature for the UPS and the batteries is between 20 and 25°C. In fact, if the battery has an average life of 5 years with a working temperature of 20°C, the life is halved if the working temperature is increased to 30°C.

- Avoid installing the equipment in places exposed to the direct sunlight or hot air

To keep the temperature of the installation room within the range indicated above, there must be a system for eliminating the dissipated heat (the UPS kW / kcal/h / B.T.U./h dissipation values are shown in the table on the previous page). The methods that may be used are:

- *Natural ventilation*
- *Forced ventilation*, recommended if the outside temperature is less (e.g. 20°C) than the temperature at which the UPS or Battery Box is to be operated (e.g. 25°C)
- *Air-conditioning system*, recommended if the outside temperature is higher (e.g. 30°C) than the temperature at which the UPS or Battery Box is to be operated (e.g. 25°C)

INTERNAL BATTERIES



CAUTION: If the UPS has INTERNAL BATTERIES, follow all the PRECAUTIONS AND SAFETY RULES listed below.

- The UPS has HAZARDOUS electrical voltages inside it, even when the input and/or battery switches are off. The inside of the UPS is protected by safety panels which should not be removed by untrained personnel. All installation and maintenance or operations involving access inside the UPS require the use of tools and may ONLY be performed by trained personnel.
- The UPS contains an internal source of energy: batteries. All terminals and sockets may be live even without connecting the UPS to the mains.
- The total battery voltage may be potentially dangerous: it may generate an electric shock. The battery compartment is protected by safety panels which should not be removed by untrained personnel. All installation and maintenance of the batteries involve access inside the UPS and require the use of tools: such operations may ONLY be performed by trained personnel.
- Replaced batteries must be considered TOXIC WASTE and treated accordingly. Do not dispose of batteries in a fire: they may explode. Do not attempt to open the batteries: they are maintenance-free. In addition, the electrolyte is harmful to the skin and eyes and can be toxic.
- Do not turn on the UPS if it is leaking fluid or if you see a residual white powder.
- Do not allow water, liquids in general and/or other foreign objects to get inside the UPS.
- Do not open the battery fuse holder while the UPS is powering the load in battery operation mode. The interruption of the battery DC may cause an electrical arc resulting in broken equipment and/or fire. In addition, if there is no mains power, the energy to power the load is provided by the batteries, therefore opening the battery caps would lead to the shutdown of the load.
- Follow these recommendations when working on the batteries:
 - Remove wristwatches, rings and other metal objects
 - Use tools with insulated handles
 - Wear rubber shoes and gloves
 - Do not lay tools or metal objects on top of the batteries
 - Disconnect the charging source before connecting or disconnecting the battery terminals
 - Check whether the battery has been inadvertently earthed. If this is the case, disconnect the source from earth. Contact with any part of the earthed battery may cause an electric shock. The likelihood can be reduced if the earthing connections are interrupted during installation and maintenance (applicable to remote battery-powering and equipment, without earthing circuits).
- Risk of explosion if the battery is replaced by another of the incorrect type. Refer to the following table to identify the correct quantities and models:

Battery Type	12V Valve regulated sealed lead-acid rechargeable
Maximum number of batteries positive branch	20+20
Maximum number of batteries negative branch	20+20
Total rated battery voltage Positive branch	240 VDC
Total rated battery voltage Positive branch	240 VDC

For correct interconnection of the batteries, refer to the wiring diagrams available to service personnel only or to the battery kit installation manual.

REMOVING THE UPS AND THE BATTERY BOX FROM THE PALLET

MCT VERSION

- Cut the straps and remove the cardboard box by sliding it upwards
- Remove the accessory box and side blocks.
NOTE 1: You will find the accessory box either inside the door of the UPS or on top of the UPS.

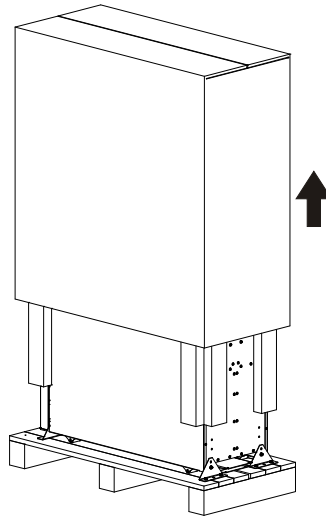

FRONT VIEW

REAR VIEW

- Open the door and remove the slides.
NOTE 2: The slides are fixed to the pallet by a screw (marked C in the figure).
- Remove the 4 brackets securing the UPS to the pallet (the screws are marked A and B in the figures).

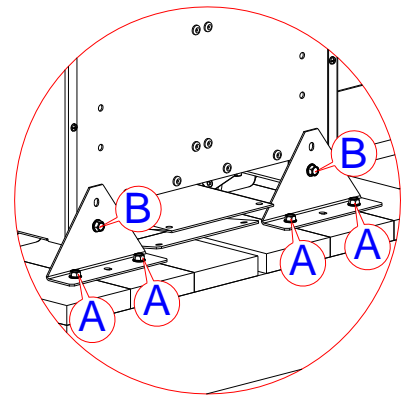
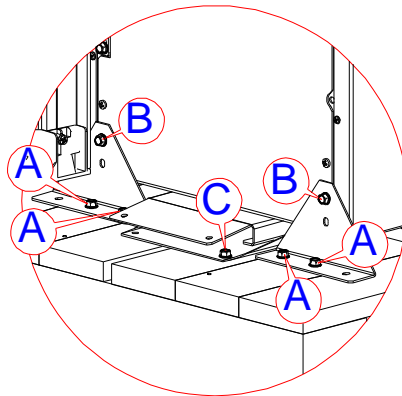

- Using 4 of the previously removed screws (type A) secure the slides to the pallet (as shown). Push the UPS from the rear off the pallet with great care. **Make sure that the door is closed before doing this**

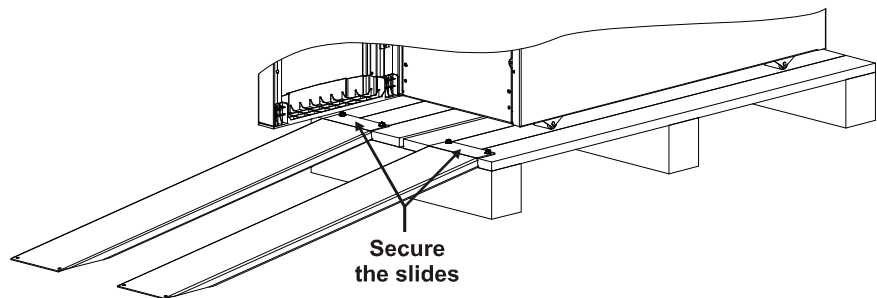

NOTE: All parts of the packaging should be kept for future use.

MST VERSION



WARNING: IN ORDER TO AVOID DAMAGE TO PERSONS AND/OR TO THE MACHINES, PLEASE FOLLOW SCRUPULOUSLY THE INDICATIONS GIVEN BELOW.



SOME OF THE FOLLOWING OPERATIONS REQUIRE TWO PEOPLE.

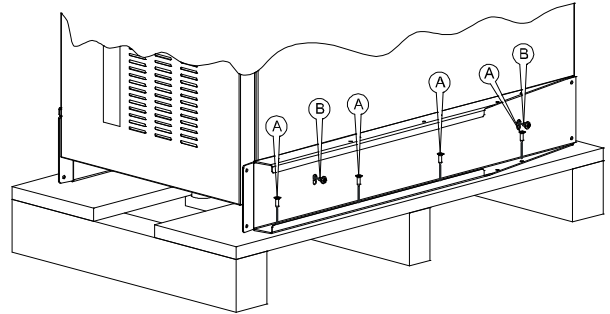
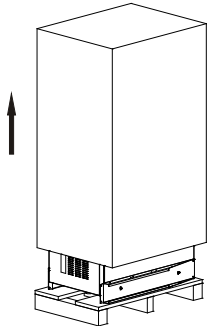

- Cut the straps and slide the cardboard box off the unit pulling upwards. Remove the packaging.
- Remove the box containing the accessories. NOTE: The box of accessories may be inside the packaging or behind the UPS door.
- Remove the two brackets securing the UPS to the pallet by loosening screws A and B.

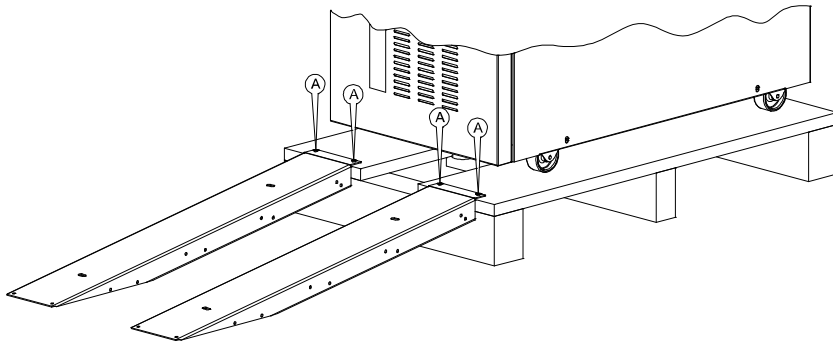

- Once removed, the two brackets can be used as ramps. Fasten the ramps to the pallet using the screws A and making sure to align them with the wheels of the unit.

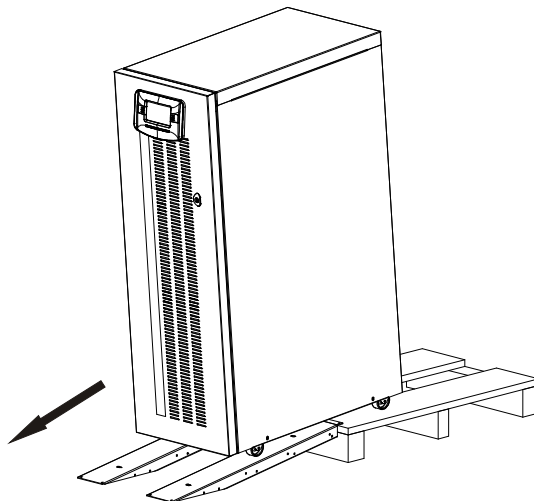

- Turn the feet as far as they will go in order to increase the distance between the unit and the pallet.
- Make sure that the door is properly closed.
- **WARNING:** to unload the UPS from the pallet, we recommend that you push it down the ramps from behind, taking every precaution and accompanying the unit along the ramps to the floor. In view of the weight of the machine, this operation should be carried out by two people.

NOTE: We advise you to keep all the parts of the packaging for future use.

PRELIMINARY CHECK OF CONTENTS

Having opened the package, start by checking the contents.

UPS
Metal slides, Guarantee document, User manual, Serial connecting cable, 4 battery fuses (to be inserted in the "SWBATT" fuse holders), Front door key (<i>MST version only</i>)

BATTERY BOX (optional)
Metal slides, Guarantee document, 4 battery fuses (to be inserted in the "SWBATT" fuse holders), Front door key (<i>MST version only</i>)

INSTALLING THE UPS AND THE BATTERY BOX

When installing the equipment, the following points should be considered:

- The wheels are to be used exclusively for fine positioning, and thus for small distances only.
- The plastic parts and the door are not to be used for gripping or pushing the UPS.
- Sufficient space should be left in front of the equipment for it to be turned on/off and maintenance operations to be performed on it (≥ 1.5 mt)
- The rear part of the UPS should be set at least 30 cm from the wall, to enable the air blown by the ventilation fans to flow away correctly
- No objects should be left on its top surface

Having set the equipment in position, secure it by engaging the brake rod (see "Front Views of the UPS" point 8) situated below the connecting terminals.

(MST version only): In seismic areas or for mobile systems, the brackets used to fasten the unit to the pallet (ramps) can be reused to anchor the UPS to the floor (see the figure below). In normal conditions, the brackets are not necessary.

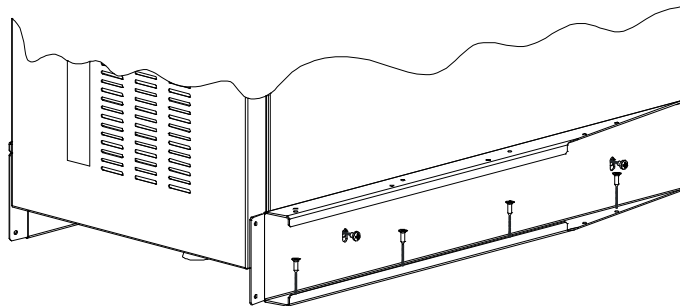

STEPS TO BE TAKEN TO GAIN ACCESS TO THE TERMINALS OF THE UPS / BATTERY BOX



The operations indicated below are to be performed with the UPS disconnected from the mains powers, turned off and with all the switches and fuse holders of the equipment open.

Follow the instructions provided below to open the UPS:

- Open the door
- Remove the terminal and switches cover (see "Views of the UPS" ref. 7)

Having completed the installation operations inside the equipment, replace the terminal cover and close the door.

ELECTRICAL CONNECTIONS



WARNING: a 4-wire three-phase distribution system is required.

The UPS must be connected to a power supply line made up of 3 phases + neutral + PE (protective earth) of TT, TN or IT type. Therefore, the phase rotation must be respected.

Optional TRANSFORMER BOXES to convert the distribution systems from 3 wires to 4 wires are available.

WIRING DIAGRAMS FOR CONNECTING TO THE ELECTRICAL SYSTEM

UPS without any variation in neutral condition

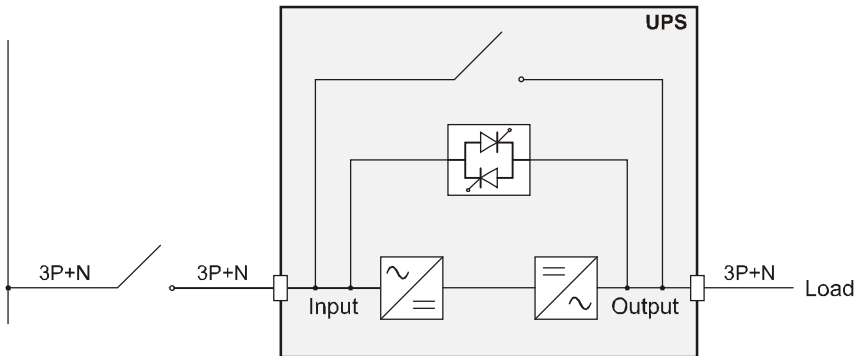

UPS with galvanic isolation at input

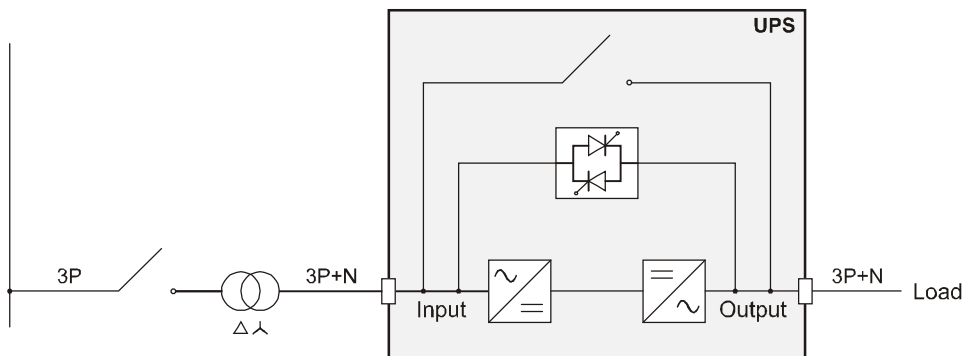

UPS with galvanic isolation at output

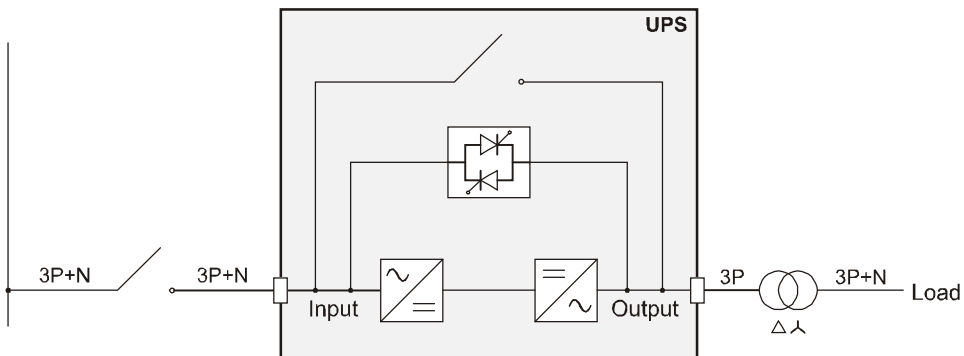

UPS without any variation in neutral condition and with separate bypass input

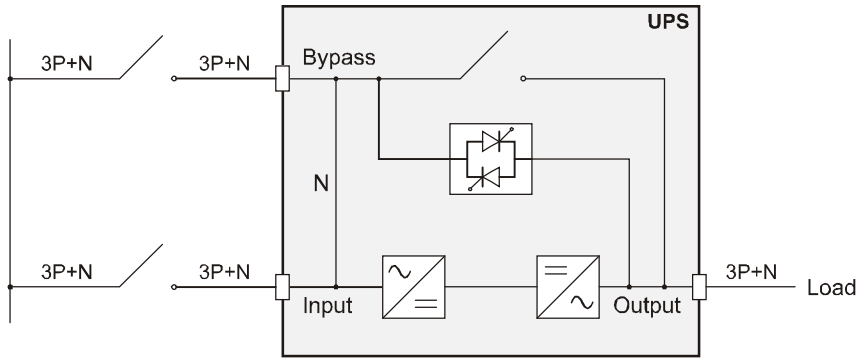

UPS with galvanic isolation and with separate bypass input

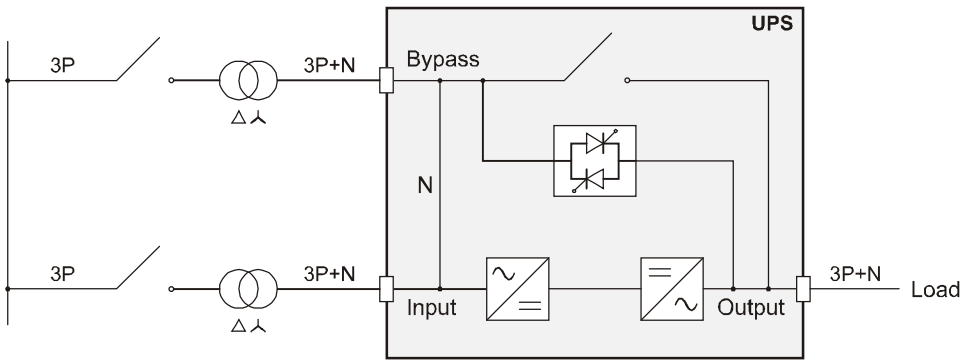

UPS with galvanic isolation at output and separate bypass input

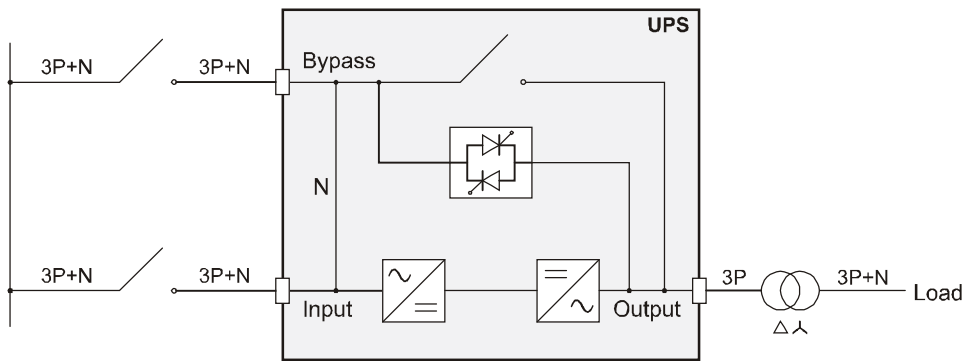

Separate bypass:

if the separate bypass option is present, protective devices must be present on both the main power supply line and the bypass line.

Note: the neutral of the input line and that of the bypass are commoned inside the equipment, so they must refer to the same potential. If the two power supplies were different, an isolation transformer would have to be used on one of the inputs.

UPS without any variation in neutral condition and with separate bypass input connected to independent power supply line

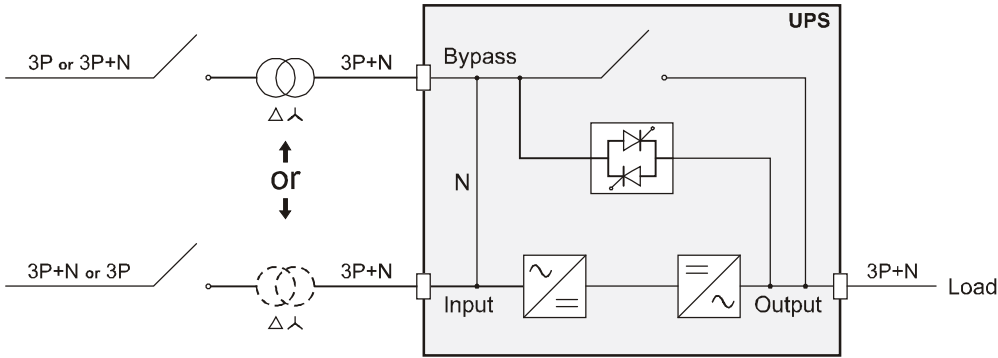

UPS with separate bypass input on independent power supply line and with galvanic isolation at input

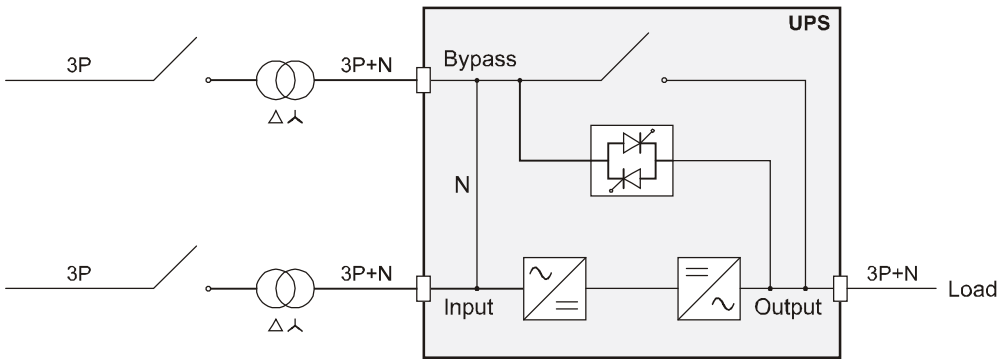

UPS with separate bypass input connected to independent power supply line and with galvanic isolation at output

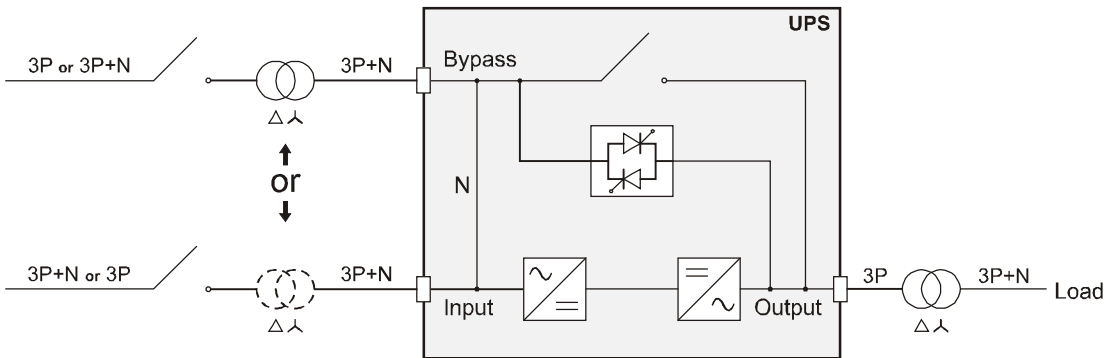

INTERNAL PROTECTIVE DEVICES OF THE UPS

The table below shows the sizes of the isolators of the UPS and the sizes of the battery fuses (SWBATT): these devices are accessible from the front of the UPS.

There are also indications about the internal fuses (not accessible) protecting the input and output lines and the maximum input and rated output currents. To install the UPS, see the block diagram in the "USE" section of the "Description" paragraph. Fuses are to be replaced with ones of the same size and the characteristics indicated in the table below.

Isolators and internal protective devices							
UPS mod.	Non-automatic switches		Fuses				
[kVA]	UPS input / Separate bypass	UPS output / Maintenance	Rectifier input fuse	Battery fuse	Output fuse	Input current [A] **	Output current [A]
	SWIN / SWBYP (optional)	SWOUT / SWMB		SWBATT		Max *	Rated
10	40A(4P)	40A(4P)	25A FF 500V (6.3x32)	32A gG 400V (10x38)	25A FF 500V (6.3x32)	20A	15A
12	40A(4P)	40A(4P)	25A FF 500V (6.3x32)	32A gG 400V (10x38)	25A FF 500V (6.3x32)	24A	17A
15	63A(4P)	63A(4P)	2 x 20A FF 500V (6.3x32)	50A gG 400V (14x51)	2 x 20A FF 500V (6.3x32)	29A	22A
20	63A(4P)	63A(4P)	2 x 20A FF 500V (6.3x32)	50A gG 400V (14x51)	2 x 20A FF 500V (6.3x32)	38A	29A

* The max. input current refers to a rated load (PF = 0.9) and an input voltage of 346V, and a battery charger charged with 4A.

** In versions with additional internal battery chargers (optional), the maximum input current on lines L2 and L3 must be increased by 7A.

SHORT CIRCUIT

If a failure occurs on the load, the UPS protects itself by limiting the value and duration of the current output (short-circuit current). These values also depend on the operating status of the UPS at the time of the failure; there are two different cases:

- UPS in NORMAL OPERATION: the load is switched instantaneously to the bypass line ($I^2t=11250A^2s$): the input line is connected to the output without any internal protection (blocked after $t>0.5s$)
- UPS in BATTERY OPERATION: the UPS protects itself by providing a current equivalent to about 1.5 times the rated current for 0.5s and turns itself off after this time has elapsed

BACKFEED

The UPS has internal protection against backfeed through metal separating devices.

There is an output on the relay board (optional) for activating a releasing device to be installed upstream from the UPS.



The UPS has an internal device (redundant bypass power supply) which, when a failure occurs on the machine, activates the bypass automatically, thus keeping the load powered without any internal protection and without any limitation to the power supplied to the load.

Under these emergency conditions, any disturbance present on the input line will affect the load.

See also the "USE" section of the "Redundant Auxiliary Power Supply for Automatic Bypass" paragraph.

EXTERNAL PROTECTIVE DEVICES

MAGNETOTHERMAL

As explained previously, the UPS has protection devices for output faults as well as for internal faults. In order to set up the power line, install a magnetothermal switch upstream from the UPS with intervention curve B or C. Please follow the indications in the table below:

Automatic external protective devices		
UPS mod.	Mains input	Separate bypass input (optional)
10 kVA	40A	40A
12 kVA	40A	40A
15 kVA	63A	63A
20 kVA	63A	63A



If the protective device upstream from the UPS interrupts the neutral wire, it must also interrupt all the phase wires at the same time (four-pole switch).

Output protections (recommended values for discrimination)		
Normal fuses (GI)	In (Nominal current)/7	In (Nominal current)/7
Normal switches (C curve)	In (Nominal current)/7	In (Nominal current)/7
Ultra-fast fuses (GF)	In (Nominal current)/2	In (Nominal current)/2

DIFFERENTIAL

In versions with no input separation transformer, the neutral from the mains power supply is connected to the UPS output neutral; as a result, there will be no change to the neutral arrangements of the installation:

THE UPS INPUT NEUTRAL IS CONNECTED TO THE UPS OUTPUT NEUTRAL THE DISTRIBUTION SYSTEM THAT POWERS THE UPS IS NOT MODIFIED BY THE UPS



The neutral condition is only modified if an isolation transformer is present or when the UPS works with a neutral isolated upstream.
Make sure that the equipment is connected correctly to the input neutral because as damage may be caused to the UPS.

During operation with the mains supply present, a differential switch (RCD) at the input to the UPS will activate should a fault occur on the output side as the output circuit is not isolated from the input circuit. In any case, other differential switches may still be installed on the output, preferably in coordination with those present at the input.

The differential switch located upstream must have the following characteristics:

- Differential current adjusted to the sum of UPS + Load; we recommend a suitable margin be kept to prevent unwanted activation (100mA min. - 300mA recommended)
- Type B
- Delay of at least 0.1s

CROSS SECTION OF THE CABLES

We recommend the INPUT/OUTPUT and BATTERY cables be passed under the UPS.
To determine the minimum cross section of the input and output cables, see the table below:

Cross section of cables (mm ²)*									
kVA	INPUT mains / separate bypass (optional)			OUTPUT			BATTERY** (optional)		
	PE	L1/L2/L3	N	PE	L1/L2/L3	N	PE	+/-	N
10	4	2.5	4	4	2.5	4	4	4	4
12	6	4	6	6	4	6	6	6	6
15	6	4	6	6	4	6	6	6	6
20	10	6	10	10	6	10	10	10	10

* The cross sections indicated in the table refer to a maximum length of 10 metres

** The maximum length of the cables for connecting the Battery Box (optional) is 3 metres

Note: the maximum cross section of the cables that may be inserted in the terminal board is:

- 10mm² for cables with lugs
- 16mm² for bare cables

CONNECTIONS



The first wire to be connected is the protective earth wire, which is to be inserted in the terminal marked PE. During operation the UPS must be connected to the earthing system

Connect the input and output cables to the terminal board as indicated in the figure below:



THE INPUT NEUTRAL MUST ALWAYS BE CONNECTED

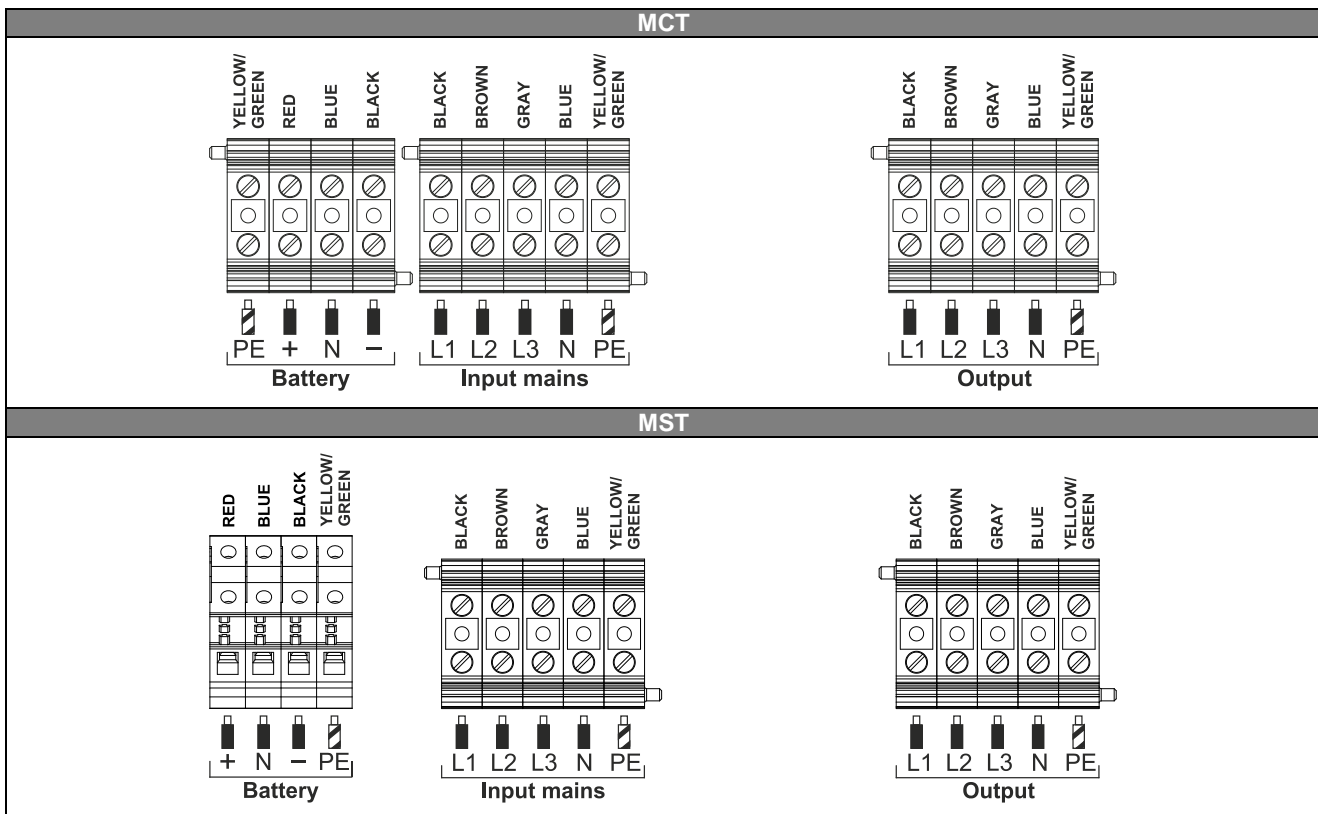

Note: the connections to the BATTERY module must only be made if the Battery Box (optional) is present.

CONNECTIONS OF THE MODEL WITH SEPARATE BYPASS



The first wire to be connected is the protective earth wire, which is to be inserted in the terminal marked PE. During operation the UPS must be connected to the earthing system

Connect the input and output cables to the terminal board as indicated in the figure below:



**THE INPUT AND BYPASS NEUTRALS MUST ALWAYS BE CONNECTED.
THE INPUT AND BYPASS LINES MUST REFER TO THE SAME NEUTRAL POTENTIAL.**

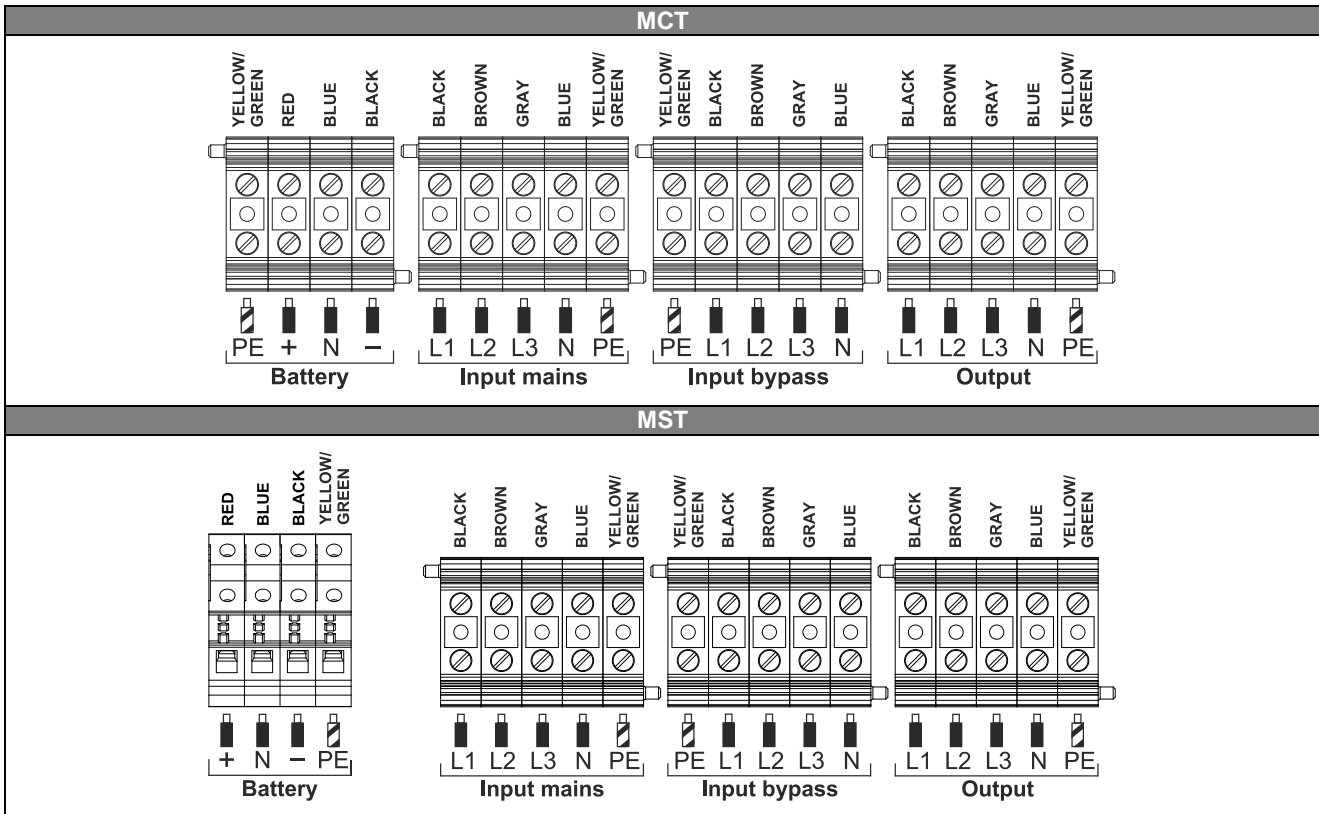

Note: the connections to the BATTERY module are only to be made if the (optional) Battery Box is present.

R.E.P.O.

This isolated input is used to turn off the UPS remotely in case of emergency.

The UPS is supplied from the factory with the "Remote Emergency Power Off" (R.E.P.O.) terminals short-circuited (see "View of UPS connections" ref.15). If it is to be installed, remove the short-circuit and connect to the normally closed contact of the stop device using a cable that provides a double isolation connection.

In case of emergency, by activating the stop device, the R.E.P.O. control is opened and the UPS enters stand-by mode (see "USE" section), and powers off the load completely.

The R.E.P.O. circuit is self-powered with SELV type circuits. No external power supply voltage is therefore required. When it is closed (normal condition), a maximum current of 15mA is present.

EXTERNAL SYNC

This non-isolated input is used to synchronise the inverter output with an appropriate signal coming from an external source.

For the installation:

- use an isolation transformer with an isolated single-phase output (SELV) comprised in the range 12-24Vac with $\geq 0.5\text{VA}$ power
- connect the transformer secondary to the "EXTERNAL SYNC" terminal (see "View of UPS connections" ref.19) using a double isolation cable with a 1mm^2 cross-section. Make sure to respect the polarisation as in the figure below.

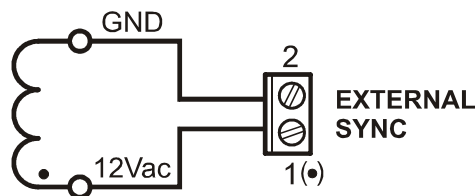

After installation, enable the control using the configuration software.

CONNECTING THE REMOTE MAINTENANCE BYPASS

An additional maintenance bypass may be installed on a peripheral switchboard, for example, to enable the UPS to be replaced without interrupting the power supply to the load.



It is absolutely essential to connect the "SERVICE BYPASS" terminal (see "View of UPS connections" ref. 17) to the auxiliary contact of the SERVICE BYPASS switch. Closing the SERVICE BYPASS switch (4) opens this auxiliary contact which informs the UPS that the maintenance bypass has been activated. If this connection is not present, the power supply to the load may be shut off and the UPS damaged.

NOTES: Use cables with a cross section that conforms to the indications given in "Cross Section of the Cables ".
Use a double insulated cable with a cross section of 1mm² to connect the "SERVICE BYPASS" terminal to the auxiliary contact of the remote maintenance bypass isolator.

Whenever the UPS is equipped with internal isolation transformer, check the compatibility between the "remote maintenance bypass" and the neutral arrangement in the electrical plant.

REMOTE MAINTENANCE BYPASS INSTALLATION DIAGRAM ON THE THREE-PHASE-THREE-PHASE MODEL

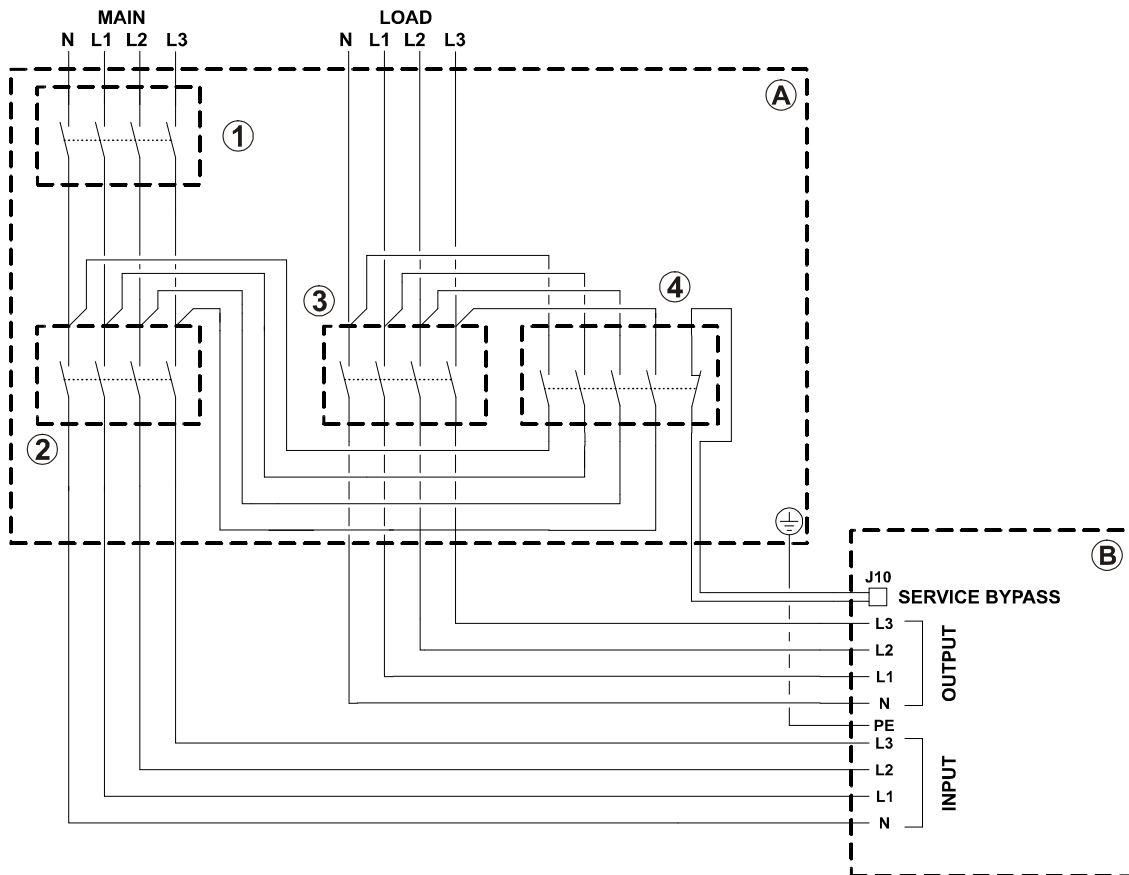

- (A)** Peripheral switchboard
- (B)** Internal connections of the UPS
- (1)** LINE switch: automatic circuit breaker, must conform to the indications given in "External Protective Devices "
- (2)** INPUT switch: isolator conforming to the indications given in "Internal Protective Devices of the UPS"
- (3)** OUTPUT switch: isolator conforming to the indications given in "Internal Protective Devices of the UPS"
- (4)** SERVICE BYPASS switch: isolator conforming to the indications given in "Internal Protective Devices of the UPS" equipped with a normally closed auxiliary contact

REMOTE MAINTENANCE BYPASS INSTALLATION DIAGRAM ON THE THREE-PHASE-THREE-PHASE WITH SEPARATE BYPASS MODEL

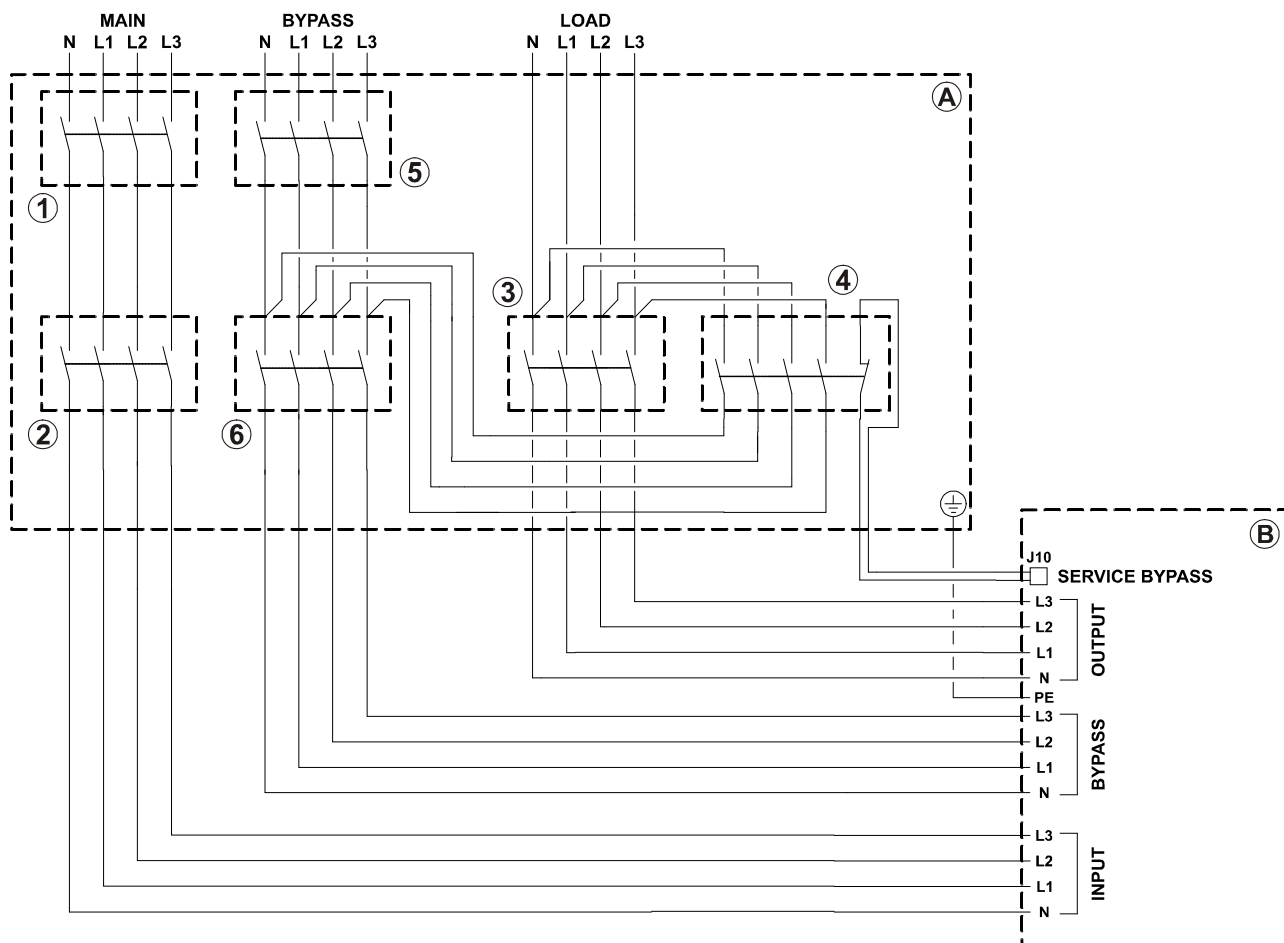

- (A)** Peripheral switchboard
- (B)** Internal connections of the UPS
- (1)** MAIN LINE switch: automatic circuit breaker, must conform to the indications given in "External Protective Devices "
- (2)** INPUT switch: isolator conforming to the indications given in "Internal Protective Devices of the UPS"
- (3)** OUTPUT switch: isolator conforming to the indications given in "Internal Protective Devices of the UPS"
- (4)** SERVICE BYPASS switch: isolator conforming to the indications given in "Internal Protective Devices of the UPS" equipped with a normally closed auxiliary contact
- (5)** BYPASS LINE switch: automatic circuit breaker, must conform to the indications given in "External Protective Devices "
- (6)** BYPASS INPUT switch: isolator conforming to the indications given in "Internal Protective Devices of the UPS"

CONNECTING THE BATTERY BOX TO THE UPS



THE CONNECTION BETWEEN THE UPS AND THE BATTERY BOX MUST BE MADE WITH THE DEVICES POWERED OFF AND UNPLUGGED FROM THE MAINS

UPS POWER-OFF PROCEDURE:

- Turn off all devices connected to the UPS or use the remote bypass option (if installed).
- Turn off the UPS following the relevant power-off procedure (see the "USE" section of the "Powering off the UPS" paragraph).
- Open all the isolators and fuse holders present in the UPS.
- Isolate the UPS completely from the electricity network by opening all the external protective devices situated on the input and output lines
- Wait a few minutes before proceeding to work on the UPS.
- Remove the terminal cover of the UPS (see "Operations to access the UPS/Battery Box terminals).

CONNECTING THE BATTERY BOX:

- Check that the battery voltage of the Battery Box corresponds to that allowed by the UPS (check the data plate on the Battery Box and the manual of the UPS)
- **IMPORTANT:** make sure that the fuse holders of the UPS and the Battery Box are open.
- Remove the terminal cover of the Battery Box (see "Operations to access the UPS/Battery Box terminals).
- Connect the earth terminals of the UPS and the Battery Box using the yellow/green wire of the cable provided.
- Connect the terminals to the UPS and the Battery Box:
 - terminals marked with the + symbol with the red cable
 - terminals marked with the **N** symbol with the blue cable
 - terminals marked with the – symbol with the black cablerespecting the correspondence indicated by the symbols print on the terminal cover of the Battery Box and the UPS.
- Reposition the terminal covers removed previously.

CHECKING INSTALLATION:

- Insert the fuses in the SWBATT fuse holders of the Battery Box.
- Close the SWBATT fuse holders of the Battery Box and the UPS.
- Carry out the UPS power-on procedure described in this manual.
- After about 30 sec., check that the UPS is working properly: simulate a black-out by opening the SWIN input isolator of the UPS. The load must continue to be powered, the "battery power" LED must light up on the control panel of the UPS, and the latter will emit a beep at regular intervals. When the SWIN input isolator is closed again, the UPS must resume operation on mains power.

EXTERNAL TEMPERATURE PROBE

This **NON ISOLATED** input may be used to measure the temperature inside a remote Battery Box.



The special kit provided by the manufacturers must be used: any methods not conforming to specifications may cause faults or breakdowns in the equipment.

To install, connect the cable included in the special kit to the "EXT BATTERY TEMP PROBE" connector (see "View of the UPS Connections" ref. 3).

After installation, enable the outdoor temperature measuring function using the configuration software.

REMOTE PANEL (OPTIONAL)

The remote panel enables the remote monitoring of the UPS and gives a real time detailed summary of the machine status. The device ensures that the operator can control the electrical values of the mains power, outputs, batteries, etc. and locate any alarm conditions.



For further information regarding the connection and use of this device, please refer to its apposite manual.

USE

DESCRIPTION

The purpose of a UPS is to ensure a perfect power supply voltage for the devices connected to it irrespective of whether mains power is present or not. Once connected and powered, the UPS generates a sinusoidal alternating voltage with a stable amplitude and frequency, irrespective of the changes and/or variations occurring on the electricity network. For as long as the UPS receives energy from the mains, the batteries are kept charged under the control of the multiprocessor board. This board also controls continuously the amplitude and frequency of the mains voltage, the amplitude and frequency of the voltage generated by the inverter, the load applied, the internal temperature and the state of efficiency of the batteries.

The block diagram below shows each of the parts that make up the UPS.

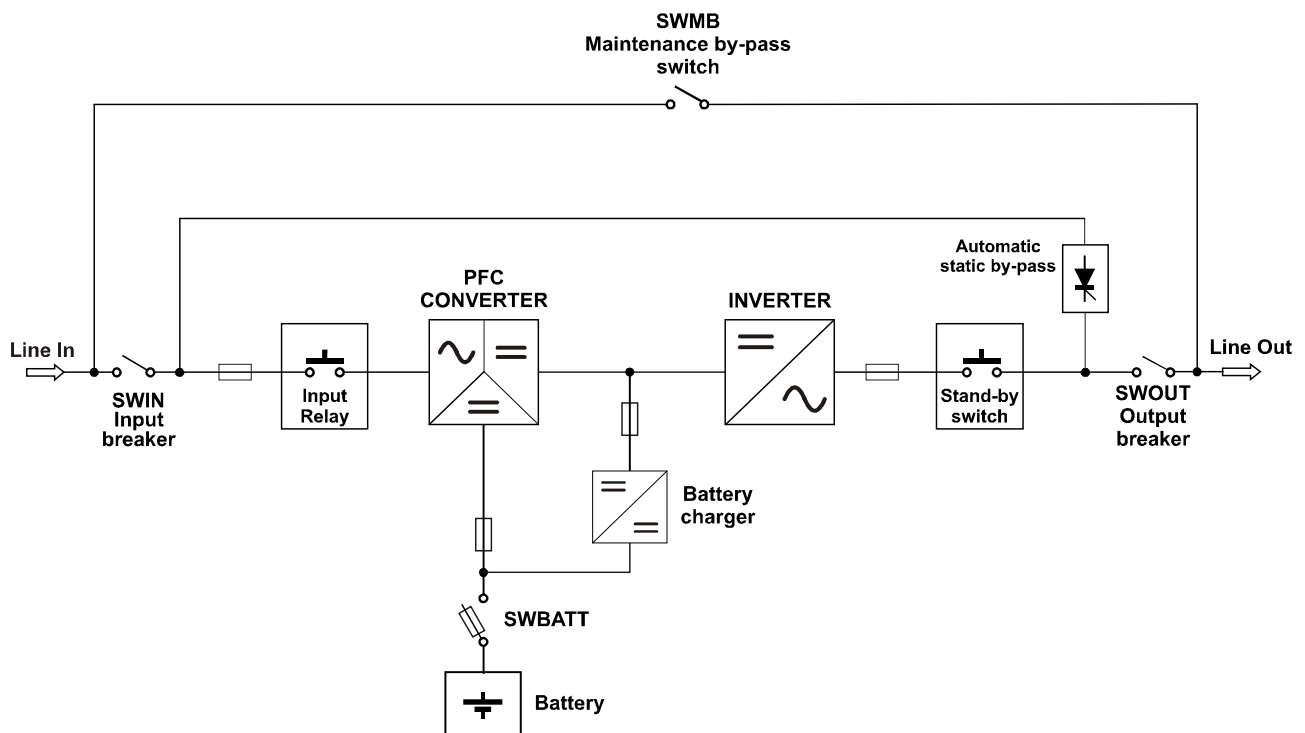

Block diagram of the UPS

IMPORTANT: Our UPS are designed and produced for long life even under the severest conditions. Remember however that they are electrical power equipment items and as such are in need of periodic checks. Besides, some components have a life cycle of their own and must therefore be checked at regular intervals and may need to be replaced, where due to the conditions: in particular, the batteries, fans and in some cases the electrolytic capacitors.

It is recommended to implement a preventive maintenance program, using manufacturer authorised and trained service personnel.

Our Technical Servicing department is at your disposal to discuss the different personalized preventive maintenance options with you.

PRELIMINARY OPERATIONS

- **Visual check of the connection**

Check that all the connections have been made strictly following the indications given in the "Connections" paragraph.

Check that the "1/0" button is in its "0" position (see "Front Views of the UPS" point 5).

Check that all the isolators are open.

- **Close the battery fuse holders**

Close the 4 battery fuse holders (SWBATT) present in the position indicated in the figure below.

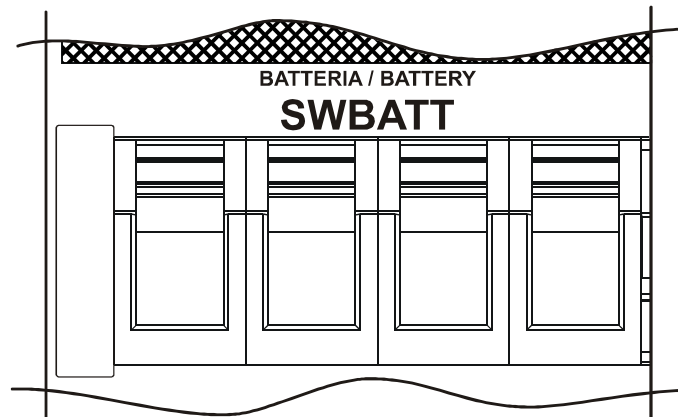

WARNING: if a battery expansion (Battery Box) has been installed incorrectly (by not following the information as provided in the "Connecting the Battery Box to the UPS" paragraph) this can lead to the battery fuses becoming damaged. If this happens, contact the customer services department immediately to avoid further damage to the UPS. Note: - When the fuses are closed, small arc flashes may occur due to the charge of the capacitors present inside the UPS. This is normal and does not cause faults and/or damage.

- **Power on the UPS**

Close the protective devices upstream from the UPS.

- **Close the input and output isolators**

Close all the input (SWIN) and output (SWOUT) isolators except for the maintenance isolator (SWMB), which is to remain open.

Note: if the separate bypass option is present, close also the bypass isolator (SWBYP).

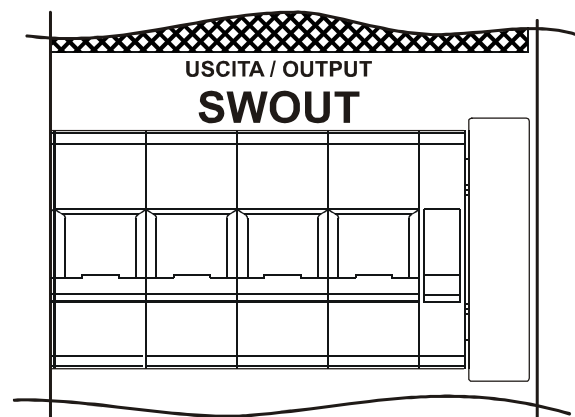
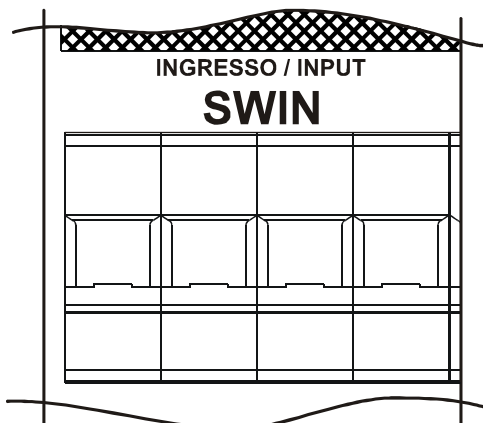

POWERING ON FOR THE FIRST TIME

- If present, set the "I/O" switch to "1" and wait for a few seconds. Check that the display is turned on and the UPS enters "STAND-BY" mode.

0. MENU		26/09/06	09:54:29
1. SYSTEM ON	5. HISTORY		
2. SYST. STAND-BY	6. WAVEFORM		
3. TEMPERATURE	7. DIAGNOSTIC		
4. COMMAND	8. CONFIGURATION		
STATUS: STAND-BY		Cod. [S09]	
		Cod. [---]	
↑	↓	↺	☰↑

Check that no error messages appear indicating that the input cables do not respect the correct phase direction. In this case, the following operations should be performed:

- Switch off the UPS by moving the "I/O" switch to "0" (if present), and open all the input and output disconnecting switches.
- Wait for the display to go off.
- Open the battery fuse holders.
- Open all the protective devices upstream from the UPS
- Remove the panel covering the input terminal board
- Correct the position of the input wires so that the phase direction is respected.
only if the separate bypass option is present: check which terminal board (input and/or bypass) the error code shown on the display corresponds to (see the "Alarm Codes" paragraph); correct the position of the wires of the terminal board indicated so that the phase direction is respected
- Close the panel again
- Repeat the power-on operations including the "preliminary operations"

- Press to enter the start menu. Choose Yes when prompted to confirm. Press to confirm and wait for a few seconds. Check that the UPS is set with the load powered by the inverter.

0. MENU		26/09/06	09:55:47
1. SYSTEM ON	5. HISTORY		
2. SYST. STAND-BY	6. WAVEFORM		
3. TEMPERATURE	7. DIAGNOSTIC		
4. COMMAND	8. CONFIGURATION		
STATUS: LOAD ON INVERTER		Cod. [S05]	
		Cod. [---]	
↑	↓	↺	☰↑

- Open the input switch (SWIN) and wait for a few seconds. Check that the UPS goes into battery-powered mode and that the load is still powered correctly. A beep should be heard approximately every 7 seconds.

0. MENU		26/09/06	09:58:13
1. S	BATTERY WORKING		
2. S			
3. T			
4. C			
STATUS: BATTERY WORKING		Cod. [S04]	
		Cod. [---]	
↑	↓	↺	☰↑

- Close the input switch (SWIN) and wait for a few seconds. Check that the UPS is not in battery-powered mode and that the load is powered correctly by the inverter.

0. MENU		26/09/06	09:59:31
1. SYSTEM ON	5. HISTORY		
2. SYST. STAND-BY	6. WAVEFORM		
3. TEMPERATURE	7. DIAGNOSTIC		
4. COMMAND	8. CONFIGURATION		
STATUS: LOAD ON INVERTER		Cod. [S05]	
		Cod. [---]	
↑	↓	↺	☰↑

- To set the Date and Time, access menu 8.6.7 (see "Display menus"). Use the up/down arrows (,) to set the desired value and then confirm with the key to move to the next field. To save the new settings, go back to the previous menu by pressing the key.

8.6.7. DATE & TIME		18/06/08	12:25:41
DATE & TIME...	18/06/08	12:24:53	
STATUS: LOAD ON INVERTER		Cod. [S05]	
		Cod. [---]	
↑	↓	↺	☰↑

POWERING ON FROM THE MAINS

- Power the UPS by closing the SWIN input switch and leaving the SWMB maintenance switch open; if present, set the "1/0" switch to "1".
After a few moments, the UPS is turned on, the capacitors are precharged and the "Lock / stand-by" LED blinks: The UPS is in stand-by mode.
- Press the **↵** button to access the power-on menu. When prompted to confirm, select "YES" and press the **↵** button again. All the LEDs around the display light up for about 1 sec. and a beep is emitted. The message "START UP" appears on the display to inform the user of the beginning of the start up sequence which ends with transition of the UPS to load powered by the inverter.

POWERING ON FROM THE BATTERY

- If present, set the "1/0" switch to "1".
- Hold the "Cold Start" key down for about 5 seconds. The UPS will start and the display will light up.
- Press the **↵** button to gain access to the power-on menu. When prompted to confirm, select "YES" and press the **↵** again. All the LEDs around the display light up for about 1 sec. and the buzzer starts to beep once about every 7 seconds.

Note: if the sequence described above is not executed within 1 min., the UPS turns itself off to avoid discharging the batteries unnecessarily.

POWERING OFF THE UPS

From the main menu, select "OFF" and press **↵** to enter the submenu. Then select the option "YES – CONFIRM" and press **↵**. To shut down the UPS completely, set the "1/0" switch (if present) to "0" and open the SWIN input switch.



Note: during prolonged periods of inactivity, it is good practice to shut down the UPS using the "1/0" switch (if present); open the input and output switches and lastly, with the UPS off, open the battery fuse holders.

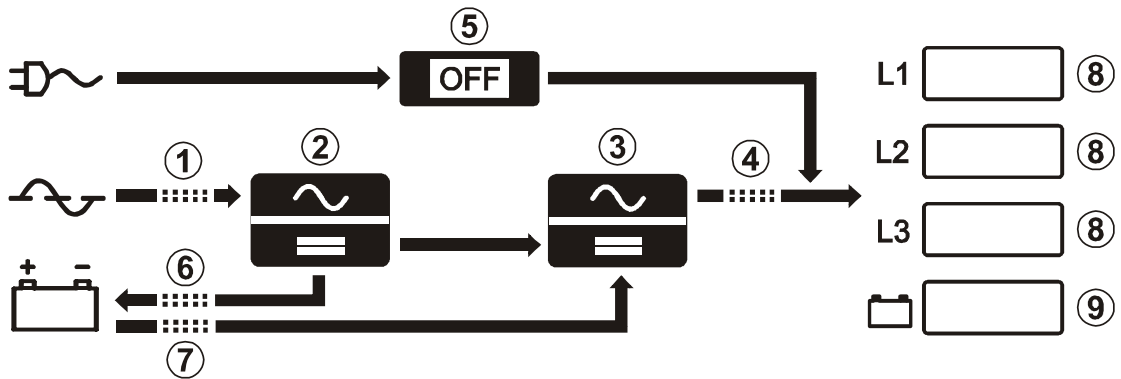

GRAPHIC DISPLAY

At the centre of the control panel is a wide graphic display for a constant detailed, real-time overview of UPS status. The first page is a schematic view of UPS operating status:





- | | |
|---------------------------|------------------------|
| ① Input Line | ⑥ Battery Charger Line |
| ② PFC Converter | ⑦ Battery Line |
| ③ Inverter | ⑧ % Load |
| ④ Inverter Output Line | ⑨ % Battery Charge |
| ⑤ Automatic Static Bypass | |

The diagram shows the status of the three power logical modules (PFC Converter, Inverter, Automatic Static Bypass). Each module can take on one of the following status types:

- | | |
|---|------------------------------------|
|  | Module Off |
|  | Module on in normal operating mode |
|  | Module alarm or block |

The following symbols show the power flow to and from the batteries (uncharged/charged) and the status of input and inverter contacts:

- | | |
|---|------------------------------------|
|  | Module Off |
|  | Module on in normal operating mode |

In addition, the user can switch the UPS on/Off directly from the control panel, consult network, output, battery measurements, etc.⁽¹⁾ and make the main machine settings.

The display is sub-divided into four main zones, each with its own specific role.

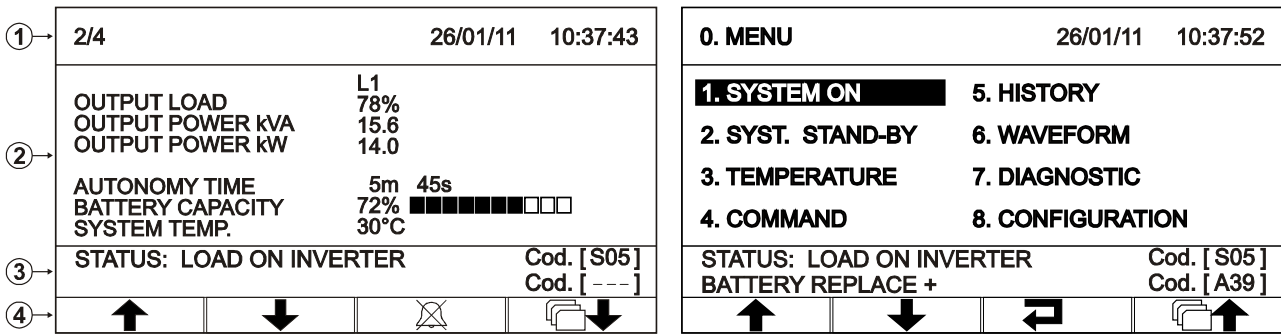

Graphic display sample screens
(screens for demonstration purposes; situations depicted may differ from reality)

1 GENERAL INFORMATION

Part of the display where the set date and hour are permanently shown and, depending on the screen, the page number or title of the menu that is active in that moment.

2 DATA VIEWING / MENU NAVIGATION

Main part of the display reserved for viewing of UPS measurements (constantly updated in real time) as well as to the consultation of various menus that can be selected by the user by means of the related function keys. Once the desired menu has been selected, this part of the display will show one or more pages containing all data relative to the selected menu.

3 UPS STATUS / ERRORS - FAULTS

UPS operation status display area.
The first row is always active and constantly displays UPS status in real time. The second is activated only in the presence of a UPS error and/or fault and shows the type of detected error/fault.
A code corresponding to the event in progress is shown to the right of each row.

4 KEYS FUNCTION

Area divided into four boxes, each relative to the underlying function key. Depending on the menu that is active in that moment, the display shows the function of the corresponding key in the related box.

Key symbols



To enter into the main menu



To return to the previous menu or display



To scroll the various selectable items inside a menu or to pass from one page to another during data display



To confirm selection



To temporarily silence the buzzer (keep press for at least 0.5 sec.).
To cancel a programmed start-up/shutdown(keep press for at least 2 sec.).

⁽¹⁾ The accuracy of the measurements is: 1% for voltage measurements, 3% for current measurements, 0.1% for frequency measurements. The indication of remaining battery time is an ESTIMATE, and is not to be considered an instrument of absolute measurement.

DISPLAY MENUS

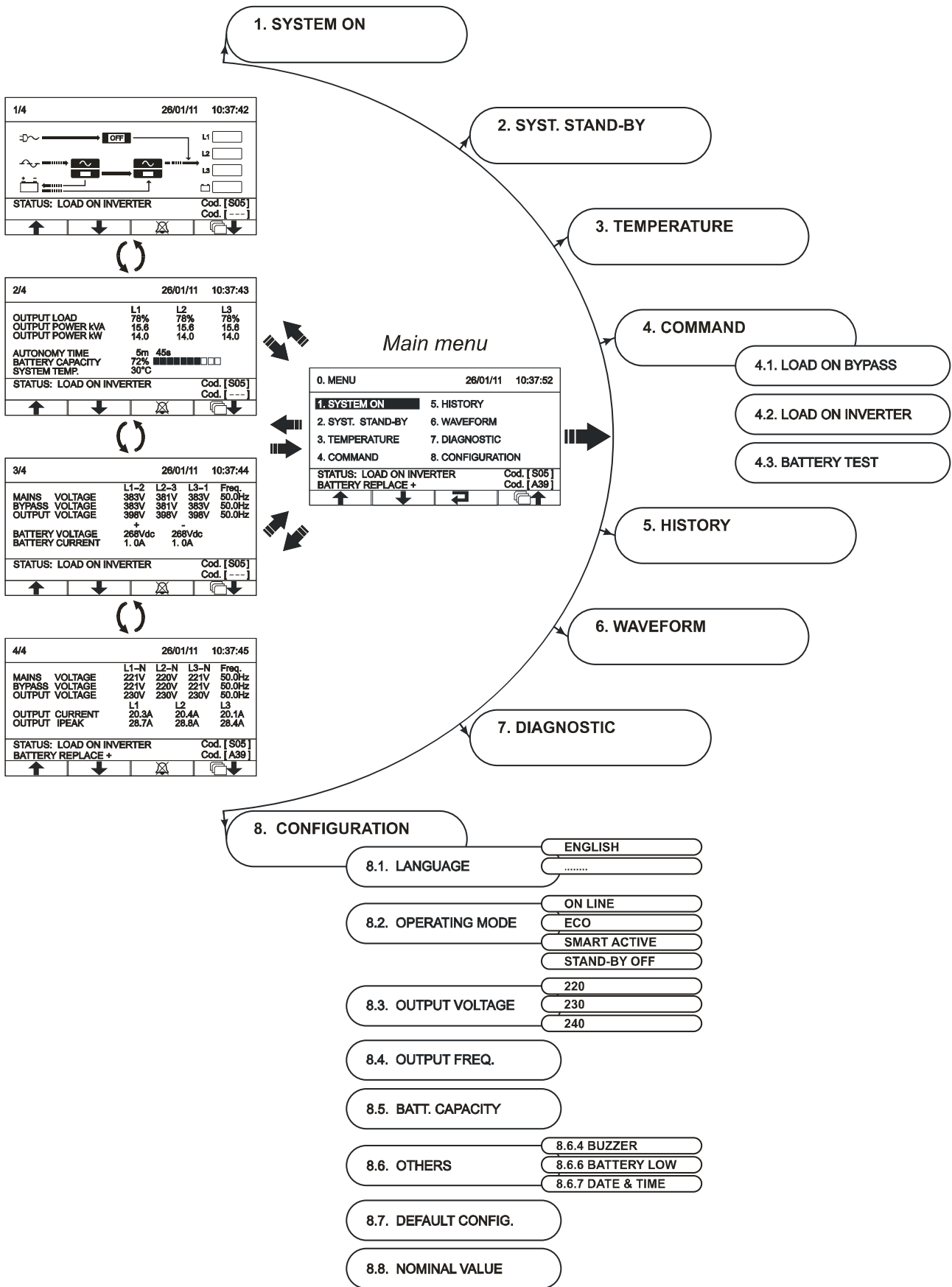

OPERATING MODES

The mode that guarantees maximum protection for the load is ON LINE mode, in which the energy for the load is converted twice and is generated perfectly sinusoidal at the output with the frequency and voltage set by the fine digital control of the DSP irrespective of the input (V.F.I.). *

In addition to the traditional, double-conversion ON LINE operating mode, the following modes may be selected:

- ECO (LINE INTERACTIVE)
- SMART (SMART ACTIVE)
- STBYOFF (STAND-BY OFF)

In order to optimize efficiency, in ECO mode, the load is normally powered from the bypass. If the mains voltage exceeds the allowed tolerance limits, the UPS switches to normal, double-conversion ON LINE mode. About five minutes after it has returned within the tolerance limits, the load is switched back to bypass.

If you are not sure which operating mode (ON LINE or ECO) to choose, the UPS may be set in SMART ACTIVE mode in which, according to statistical data on the quality of the power supply mains, the UPS autonomously decides the mode it is to enter.

Finally, in STAND-BY OFF mode, the UPS is set to operate only in an emergency:

when the mains power is present, the load is powered off while, in the event of a black-out, the load is powered by the inverter via the batteries, and is then powered off again when mains power is restored. The activation time is less than 0.5 sec.

MAINTENANCE BYPASS (SWMB)



WARNING: Maintenance work inside the UPS is to be performed exclusively by qualified staff. Inside the UPS there may be a voltage present even when the input, output and battery switches are open. Removal of the UPS panels by non-qualified staff may result in injury to the operator and damage the equipment.

Below is a list of the operations to be performed in order to carry out maintenance work on the equipment without shutting off the power supply to the load:

- The UPS must power the load via the automatic bypass or the inverter, with the mains voltage present.
N.B.: If the UPS is in battery power mode, activating the maintenance bypass entails shutting off the power supply to the load.
- Close the maintenance bypass isolator (SWMB) situated behind the door: in this way, the input is short-circuited with the output.
- Open the input switches (SWIN), output switches (SWOUT) and battery fuse holders (SWBATT) situated behind the door: The signal panel is turned off. Wait for the electrolytic capacitors on the power board to discharge (about 15 minutes) and then proceed to perform the maintenance operations.
N.B.: During this phase, with a load powered via the maintenance bypass, any disturbance on the power supply line of the UPS will affect the devices powered (The load is connected directly to the mains. The UPS is no longer active).

Having completed the maintenance operations, proceed as follows to restart the UPS:

- Close the input and output isolators, and the battery fuse holders. The signal panel is reactivated. Turn on the UPS again from the "SYSTEM ON" menu. Wait for the sequence to be completed.
- Open the maintenance bypass: the UPS resumes normal operation.

* The rms value of the output voltage is set by the fine control of the DSP irrespective of the input voltage while the frequency of the output voltage is synchronized (within a tolerance range that may be set by the user) with the input voltage to enable the bypass to be used. Outside this range, the UPS desynchronizes and returns to the rated frequency and the bypass may no longer be used (free running mode).

REDUNDANT AUXILIARY POWER SUPPLY FOR AUTOMATIC BYPASS

The UPS is equipped with a redundant auxiliary power supply that enables the UPS to run on an automatic bypass even when a failure occurs in the main auxiliary power supply. If a fault occurs in the UPS shutting off the main auxiliary power supply, the load is powered by the automatic bypass. The multiprocessor board and the control panel are not powered so the LEDs and the display are off.

AUXILIARY SOCKETS (OPTIONAL)

ENERGYSHARE

Programmable output socket (optional) which allows automatic disconnection of the load applied to it under certain operating conditions. Events that determine automatic disconnection of the EnergyShare socket can be selected by the user through the configuration software. It is possible, for example, to select detachment after a certain period of battery operation, or when the pre-alarm threshold for battery discharge has been reached, or when an overload occurs.



Notes regarding safety: if the output switch (SWOUT) is opened while the UPS is on, both sockets remain powered.

If a manual bypass switch (SWMB) is inserted, the output switch (SWOUT) is opened and the UPS switches off and both sockets will no longer be powered.

AUX OUTPUT

Output socket (optional) directly connected to the UPS output; It caters auxiliary power supply (230V / max 10A)

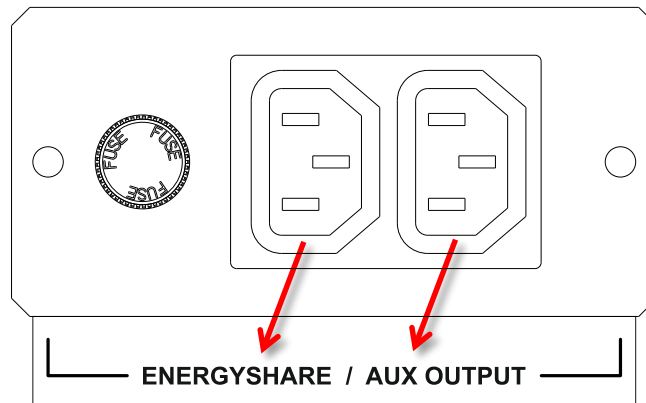

POWER WALK-IN

The UPS has a Power Walk-in mode which can be enabled and configured using the configuration software. When the mode is enabled and mains power is restored after a period of battery operation, the UPS starts to draw progressively from it so as not to stress (due to the peak) any generating set installed upstream. The transient time may be set from 1 to 125 seconds. The default value is 10 seconds (when this function is active). During the transient, the necessary power is drawn in part from the batteries and in part from the mains, maintaining sinusoidal absorption. The battery charger is turned on again once the transient has passed.

REDUCING THE LOAD (TO 200V AND 208V)

If the output voltage is set to 200V and 208V (see “Configuring the UPS” paragraph), the maximum power output of the UPS is reduced with respect to its rated value, as shown in the graph below:

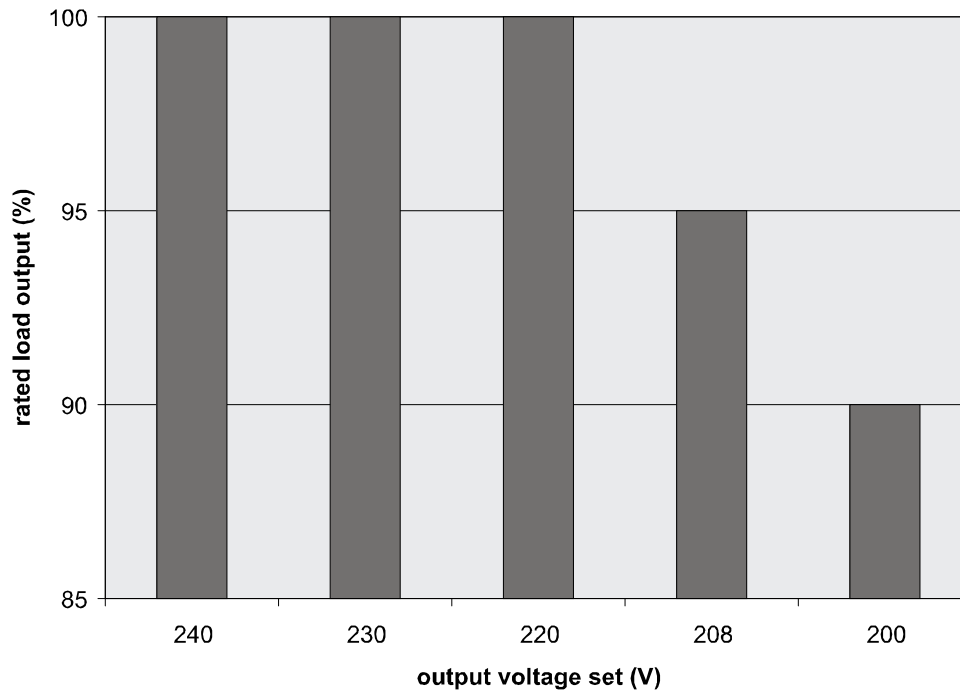

CONFIGURING THE UPS

Configurations which can be modified by the user from the control panel are listed in the table below.

FUNCTION	DESCRIPTION	DEFAULT	POSSIBLE CONFIGURATIONS
Language*	Selects mimic panel language language	English	<ul style="list-style-type: none"> English Italian German French Spanish Polish Russian Chinese
Output voltage	Selects the rated output voltage (Phase - Neutral)	230V	<ul style="list-style-type: none"> 220V 230V 240V
Buzzer	Selects the audible alarm operating mode	Reduced	<ul style="list-style-type: none"> Normal Reduced: does not sound due to the momentary intervention of the bypass
Operating mode**	Selects one of five different operating modes	ON LINE	<ul style="list-style-type: none"> ON LINE ECO SMART ACTIVE STAND-BY OFF
Battery low **	Estimated autonomy time remaining for “battery low” warning	3 min.	<ul style="list-style-type: none"> 1 ÷ 7 @1 min step
Date and time**	UPS internal watch setup		

* Press keys F1 and F4 simultaneously for $t > 2$ sec. and English will automatically be reset.

** Function modification can be blocked by means of the configuration software.

Configurations which can be modified by means of configuration software available at service centres are listed in the following table.

FUNCTION	DESCRIPTION	DEFAULT
Operating mode	Selects one of five different operating modes	ON LINE
Output voltage	Selects the rated output voltage (Phase - Neutral)	230V
Output nominal frequency	Selects the rated output frequency	50Hz
Autorestart	Waiting time for automatic power-on after the return of mains voltage	5 sec.
Auto power off	Automatic UPS power-off in battery operation mode if the charge is lower than 5%	Disabled
Buzzer Reduced	Selects the audible alarm operating mode	Reduced
EnergyShare off	Selects the auxiliary socket operating mode	Always connected
Timer	Programmed UPS power on/off (daily)	Disabled
Autonomy limitation	Maximum battery operation time	Disabled
Maximum load	Selects the user overload limit	Disabled
Bypass Synchronization speed	Selects the synchronisation speed of the inverter to the bypass line	1 Hz/sec
External synchronization	Selects the source of synchronisation for the inverter output	From bypass line
External temperature	Activates reading of the external temperature probe	Disabled
Bypass mode	Selects the mode of use of the bypass line	Enabled / High sensitivity

FUNCTION	DESCRIPTION	DEFAULT
Bypass active in stand-by	Load supply from bypass with UPS in stand-by	Disabled (load NOT supplied)
Bypass frequency tolerance	Selects the accepted range for the input frequency for switching to the bypass and for the synchronisation of the output	± 5%
Bypass min.-max. threshold	Selects the accepted voltage range for switching to the bypass	Low: 180V High: 264V
Eco mode sensibility	Selects the intervention sensitivity during operation in ECO mode	Normal
Eco mode min.-max. threshold	Selects the accepted voltage range for operation in ECO mode	Low: 200V High: 253V
UPS without battery	Operating mode without batteries (for converters or voltage stabilizers)	Operating with Batteries
Battery low time	Estimated autonomy time remaining for “battery low” warning	3 min.
Automatic battery test	Interval of time for the automatic battery test	40 ore
Parallel common battery	Common Battery for parallel UPS systems	Disabled
Internal battery capacity	Nominal Battery capacity for internal batteries	Change according with UPS model
External battery capacity	Nominal Battery capacity for external batteries	7Ah for UPS without internal batteries; 0Ah all other cases
Battery charging algorithm	Algorithm and Battery recharging threshold	Two levels
Battery recharging current	Recharging current compare to battery nominal capacity	12%

COMMUNICATION PORTS

The UPS is supplied with the following communication ports (see "Views of the UPS):

- Serial port available with RS232 connector and USB connector.
NOTE: the use of one connector automatically excludes the other.
- Port AS400
- Expansion slots for additional COMMUNICATION SLOT interface boards

On the front, covered by the terminal-cover, there is another expansion slot for the power relay board (4 programmable contacts, 250Vac, 3A)

RS232 AND USB CONNECTORS

RS232 CONNECTOR

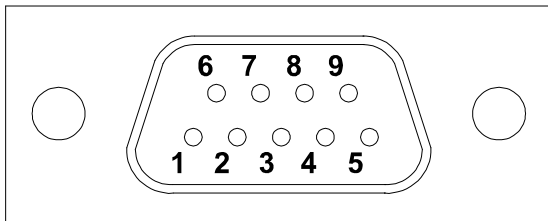

USB CONNECTOR

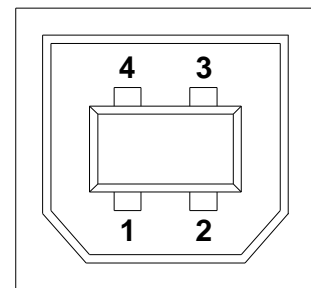

PIN #	NAME	TYPE	SIGNAL
1		IN	
2	TX	OUT	Serial line TX
3	RX	IN	Serial line RX
4			
5	GND	POWER	
6		OUT	
7			
8	+15V	POWER	Isolated power supply 15V±5% 80mA max
9	WKATX	OUT	ATX power supply wake-up

PIN #	SIGNAL
1	VBUS
2	D-
3	D+
4	GND

COMMUNICATION SLOTS

The UPS is equipped with two expansion slots for accessory communication boards that enable the equipment to communicate using the main communication standards.

Some examples:

- Second RS232 port
- Serial duplicator
- Ethernet agent with TCP/IP, HTTP and SNMP protocol
- RS232 + RS485 port with JBUS / MODBUS protocol

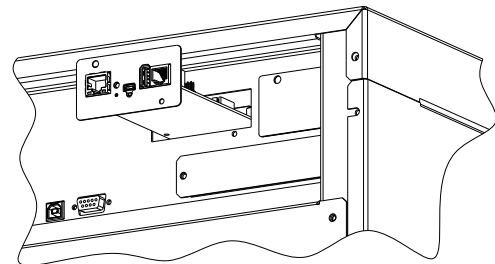

For further information on the accessories available, visit the web site.

AS400 PORT

AS400 PORT

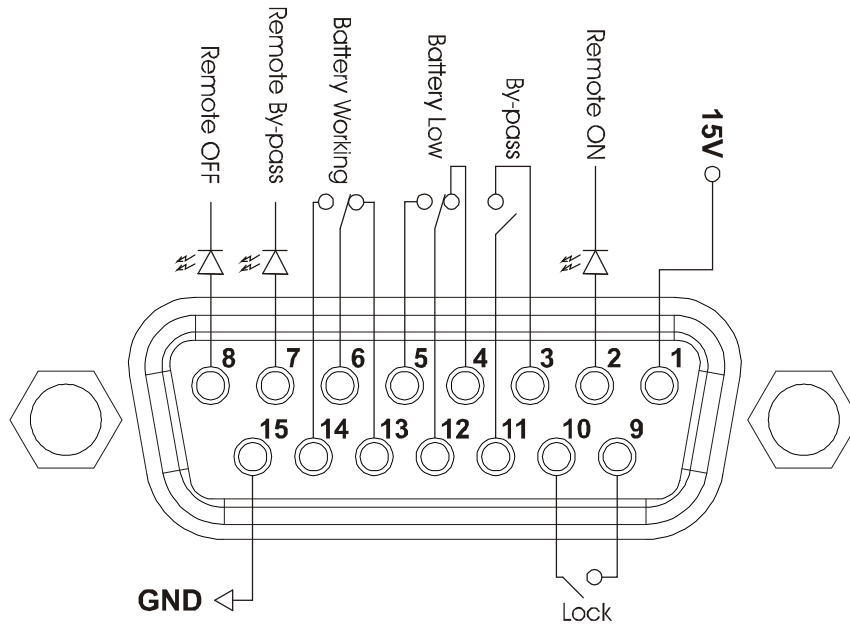

PIN #	NAME	TYPE	FUNCTION
1	15V	POWER	Isolated auxiliary power supply, +15V±5% 80mA max
15	GND	POWER	Ground to which the isolated auxiliary power supply (15V) and the remote commands (Remote ON, Remote BYPASS, Remote OFF) refer
2	REMOTE ON	INPUT #1	When pin 2 is connected to pin 15 for at least 3 seconds, the UPS is turned on
8	REMOTE OFF	INPUT #2	When pin 8 is connected to pin 15, the UPS is powered off instantly
7	REMOTE BYPASS	INPUT #3	When pin 7 is connected to pin 15, the power supply of the load switches from inverter to bypass. For as long as the connection remains, the UPS continues to operate from the bypass even if the input mains voltage is shut off. If the jumper is removed when the mains voltage is present, the UPS resumes operation from the inverter. If the jumper is removed when there is no mains voltage present, the UPS resumes operation from the battery
4,5,12	BATTERY LOW	OUTPUT #1	Indicates that the batteries are about to run out when contact 5/12 is closed ⁽¹⁾
6,13,14	BATTERY WORKING	OUTPUT #2	Indicates that the UPS is running on battery power when contact 6/14 is closed ⁽¹⁾
9,10	LOCK	OUTPUT #3	When the contact is closed, indicates that the UPS is locked ⁽¹⁾
3,11	BYPASS	OUTPUT #4	When the contact is closed, indicates that the load is powered via the bypass ⁽¹⁾

N.B.: The figure shows the contacts present inside the UPS, capable of carrying a max. current of 0.5A to 42Vdc. The position of the contacts shown in the figure is with no alarm or signal present.

⁽¹⁾ The output may be programmed using the configuration software. The function indicated is selected by default (factory setting)

BUZZER

The status and faults of the UPS are signalled by the buzzer, which will emit a sound modulated according to the operating conditions of the UPS.

The various kinds of sound are described here below:

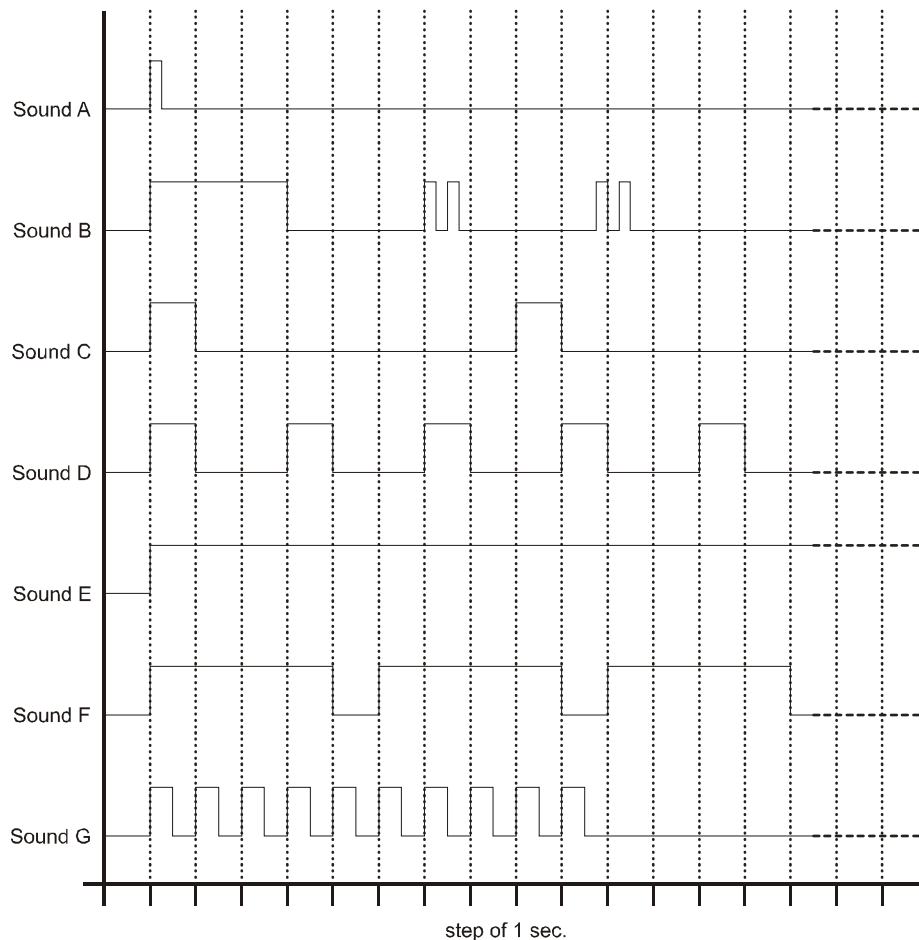

- Sound A: The signal is emitted when the UPS is turned on or off using the relevant buttons. A single beep confirms power-on, activation of the battery test, cancellation of the programmed power-off. When the power-off button is kept pressed, the buzzer emits the sound A quickly four times, before confirming power-off by emitting a fifth beep.
- Sound B: The signal is emitted when the UPS switches to bypass to compensate for the surge current due to the activation of a distorting load.
- Sound C: The signal is emitted when the UPS switches to battery operation before the battery low signal (sound D). Possibility of silencing the report (see paragraph "Graphic Display")
- Sound D: The signal is emitted during battery operation when the battery low alarm threshold is reached. Possibility of silencing the report (see paragraph "Graphic Display")
- Sound E: This signal is emitted in the presence of an alarm or lock.
- Sound F: This signal is emitted if the battery overvoltage fault occurs
- Sound G: This type of signal is emitted when the battery test fails. The buzzer emits ten beeps. The alarm signal is maintained by the "batteries to be replaced" LED lights up.

SOFTWARE

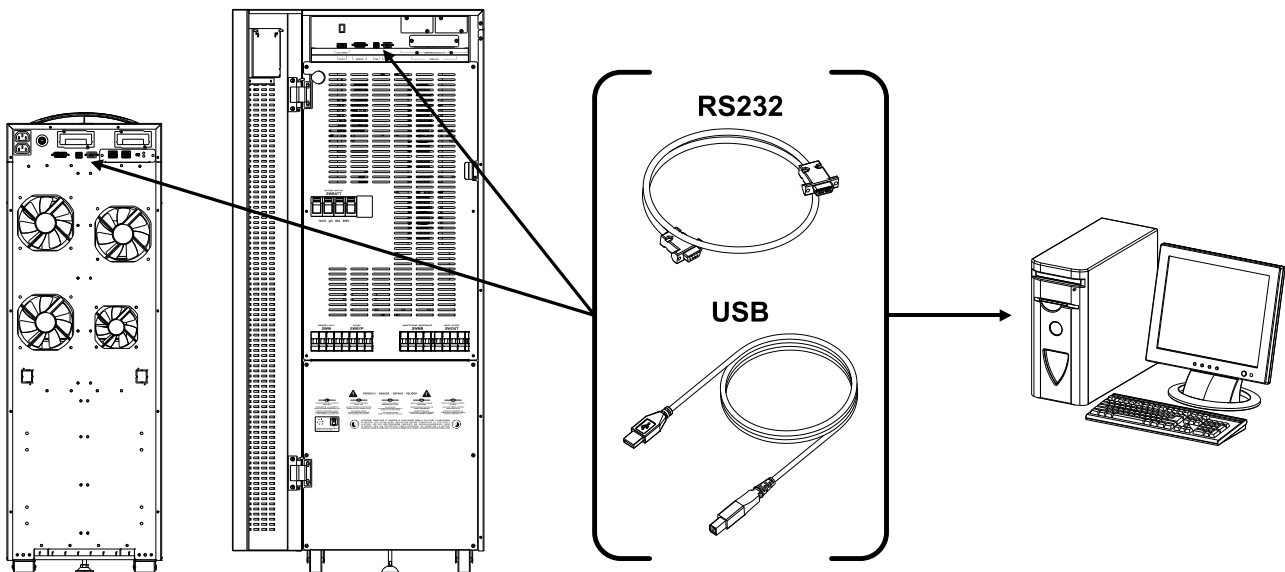

MONITORING AND CONTROL SOFTWARE

The **PowerShield³** software ensures an effective and user-friendly management of the UPS, displaying all the most important items of information such as the input voltage, load applied and battery capacity. It can also automatically perform shutdown operations, send e-mails, sms and network messages when specific user-selected events occur.

Installation operations:

- Connect the RS232 communication port of the UPS to a COM communication port of the PC via the serial cable provided* or connect the USB port of the UPS to a USB port of the PC using a standard USB cable *.
- Download the software from **www.riello-ups.com**, selecting the desired operating system.
- Follow the installation program instructions.
- For more detailed information about installation and use, refer to the software manual which can be downloaded from our website **www.riello-ups.com**.

CONFIGURATION SOFTWARE

Using special software, it is possible to configure the most important UPS parameters. For a list of possible configurations, refer to the **UPS configuration** paragraph.

* We recommend the use of a cable no longer than 3 metres.

TROUBLESHOOTING GUIDE

Irregular operation of the UPS is very often not an indication of a fault but is simply caused by simple problems or distractions. We therefore recommend you consult the table here below, which provides some information that will help you to solve the most common problems.



WARNING: the table below frequently recommends the use of the maintenance BYPASS. We remind you that before restoring the UPS to operation, you must make sure that it is on and **not in STAND-BY**. If the UPS is in this latter mode, turn on the UPS by accessing the “SYSTEM ON” menu and wait for the power-on sequence to be completed before removing the maintenance BYPASS.
For further details **read the procedures described in the maintenance BYPASS (SWMB) paragraph.**

NOTE: For a detailed explanation of the codes listed in the table, see the “STATUS/ALARM CODES” paragraph.

PROBLEM	POSSIBLE CAUSE	SOLUTION
The UPS WITH THE MAINS VOLTAGE PRESENT, DOES NOT ENTER STAND-BY MODE (THE RED LOCK/STAND-BY LED DOES NOT BLINK, NO BEEP IS EMITTED AND THE DISPLAY IS NOT TURNED ON)	NO CONNECTION WITH INPUT TERMINALS	Connect the mains to the terminals as indicated in the installation paragraph
	NO NEUTRAL CONNECTION	The UPS cannot work without a neutral connection. WARNING: If this connection is missing, damage could be caused to the UPS and/or the load. Connect the mains to the terminals as indicated in the Installation paragraph.
	1/0 SWITCH BEHIND DOOR IS SET TO 0	Set the switch to 1 (if present)
	ISOLATOR BEHIND DOOR (SWIN) IS OPEN	Close the isolator
	MAINS VOLTAGE NOT PRESENT (BLACKOUT)	Check that the mains voltage is present. If necessary, power on the UPS from the battery to power the load.
	PROTECTIVE DEVICE UPSTREAM ACTIVATED	Reset the protective device. <u>Warning:</u> check that there is no overload or short-circuit at the output of the UPS.
THE LOAD IS NOT POWERED	NO CONNECTION WITH OUTPUT TERMINALS	Connect the load to the terminals
	ISOLATOR BEHIND DOOR (SWOUT) IS OPEN	Close the isolator
	UPS IS IN STAND-BY	Execute the power-on sequence
	STAND-BY OFF MODE IS SELECTED	The mode must be changed. In fact, STAND-BY OFF (emergency) mode only powers the loads when a black out occurs.
	UPS FAILURE AND AUTOMATIC BYPASS OUT OF ORDER	Insert the maintenance bypass (SWMB) and call your local service centre
THE UPS RUNS ON BATTERY POWER EVEN WHEN THE MAINS VOLTAGE IS PRESENT	PROTECTIVE DEVICE UPSTREAM ACTIVATED	Reset the protective device. WARNING: Check that there is no overload or short circuit at the output of the UPS.
	INPUT VOLTAGE OUTSIDE TOLERANCE LIMITS FOR MAINS OPERATION	Problem caused by the mains. Wait for the input mains voltage to return within the tolerance limits. The UPS will return automatically to mains operation.

PROBLEM	POSSIBLE CAUSE	SOLUTION
THE DISPLAY SHOWS C01	THE JUMPER IS MISSING FROM THE R.E.P.O. CONNECTOR (J13, REF. 15 - "VIEW OF THE UPS CONNECTIONS") OR IS NOT INSERTED CORRECTLY	Assemble the jumper or check that it is inserted correctly.
THE DISPLAY SHOWS C05	MAINTENANCE BYPASS ISOLATOR (SWMB) CLOSED	Open the isolator (SWMB) situated behind the door.
	THE JUMPER IS MISSING FROM THE TERMINALS FOR THE REMOTE MAINTENANCE BYPASS (J10, REF. 17 - "VIEW OF THE UPS CONNECTIONS")	Insert the jumper
THE DISPLAY SHOWS ONE OR MORE OF THE FOLLOWING CODES: A30, A32, A33, A34 AND THE UPS WILL NOT START	AMBIENT TEMPERATURE < 0°C	Heat the environment, wait for the heat sink temperature to rise above 0°C and then start up the UPS
	FAULT IN TEMPERATURE PROBE ON HEAT SINK	Activate the maintenance bypass (SWMB), turn the UPS off and on again and exclude the maintenance bypass. If the problem persists, call your local service centre
THE DISPLAY SHOWS ONE OR MORE OF THE FOLLOWING CODES: F09, F10	FAULT IN THE INPUT STAGE OF THE UPS	Activate the maintenance bypass (SWMB), turn the UPS off and on again. Exclude the maintenance bypass. If the problem persists, call your local service centre
	PHASE 1 HAS A VOLTAGE MUCH LOWER THAN THE OTHER TWO PHASES.	Open SWIN, turn the UPS from the battery, wait for the end of the sequence and close SWIN
THE DISPLAY SHOWS ONE OR MORE OF THE FOLLOWING CODES: F11, F14, F15, F16, F17, L06, L07, L08, L09, L14, L15, L16, L17, L18, L19, L20, L21, L22	FAULTY LOADS APPLIED	Remove the load. Insert the maintenance bypass (SWMB), and turn the UPS off and then on again. Exclude the maintenance bypass. If the problem persists, call your local service centre
	FAULT IN THE INPUT OR OUTPUT STAGE OF THE UPS	Activate the maintenance bypass (SWMB) and turn the UPS off and then on again. Exclude the maintenance bypass. If the problem persists, call your local service centre
THE DISPLAY SHOWS ONE OR MORE OF THE FOLLOWING CODES: F03, F04, F05, A08, A09, A10	NO CONNECTION ON ONE OR MORE PHASES	Check the connections to the terminals
	INTERNAL PROTECTIVE FUSES BLOWN ON THE PHASES OR INPUT RELAY BROKEN	Call your local service centre
THE DISPLAY SHOWS ONE OR MORE OF THE FOLLOWING CODES: F42, F43, F44, L42, L43, L44	THE INTERNAL PROTECTION FUSES ON THE BATTERIES HAVE BLOWN	Call the nearest service centre.

PROBLEM	POSSIBLE CAUSE	SOLUTION
THE DISPLAY SHOWS ONE OR MORE OF THE FOLLOWING CODES: A13, A14, A15	PROTECTIVE DEVICE UPSTREAM FROM THE BYPASS LINE OPEN (ONLY IF BYPASS IS SEPARATE)	Reset the protective device upstream. WARNING: check that there is no overload or short circuit at the output of the UPS
	BYPASS ISOLATOR OPEN (SWBYP ONLY IF BYPASS IS SEPARATE)	Close the isolator situated behind the door.
THE DISPLAY SHOWS ONE OR MORE OF THE FOLLOWING CODES: F19, F20	BATTERY CHARGER FAULT	Open the battery fuse holders (SWBATT), insert the maintenance bypass (SWMB) and shut down the UPS completely. Switch on again and if the fault persists, contact the nearest technical support centre.
THE DISPLAY SHOWS ONE OR MORE OF THE FOLLOWING CODES: A26, A27	BATTERY FUSES BLOWN OR FUSE HOLDER ISOLATORS OPEN	Replace the fuses or close the isolators (SWBATT). WARNING: if necessary, we recommend fuses be replaced with others of the same type (see Internal Protective Devices of the UPS)
THE DISPLAY SHOWS THE CODE S07	THE BATTERIES ARE DISCHARGED; THE UPS WAITS FOR THE BATTERY VOLTAGE TO EXCEED THE THRESHOLD SET	Wait for the batteries to recharge or force power on from the System On menu
THE DISPLAY SHOWS ONE OR MORE OF THE FOLLOWING CODES: F06, F07, F08	INPUT RELAY LOCKED	Activate the maintenance bypass (SWMB), turn off the UPS, <u>open SWIN</u> and call your local service centre.
THE DISPLAY SHOWS ONE OR MORE OF THE FOLLOWING CODES: L01, L10, L38, L39, L40, L41	FAULT IN: <ul style="list-style-type: none"> ▪ TEMPERATURE PROBE OR UPS COOLING SYSTEM ▪ MAIN AUXILIARY POWER SUPPLY ▪ STATIC BYPASS SWITCH 	Activate the maintenance bypass (SWMB), turn the UPS off and then on again. Exclude the maintenance bypass. If the problem persists, call your local service centre
THE DISPLAY SHOWS ONE OR MORE OF THE FOLLOWING CODES: A22, A23, A24, F23, L23, L24, L25	THE LOAD APPLIED TO THE UPS IS TOO HIGH	Reduce the load to below the 100% threshold (or user threshold for the code A22, A23 or A24)
THE DISPLAY SHOWS ONE OR MORE OF THE FOLLOWING CODES: L26, L27, L28	SHORT CIRCUIT AT OUTPUT	Power off the UPS. Disconnect all the devices connected to the phase concerned by the short circuit. Power menu the UPS on again. Reconnect the devices one by one until the faulty one is identified.

PROBLEM	POSSIBLE CAUSE	SOLUTION
<p>THE DISPLAY SHOWS ONE OR MORE OF THE FOLLOWING CODES: A39, A40 AND THE RED "BATTERIES TO BE REPLACED" LED IS ON</p>	<p>THE BATTERIES HAVE FAILED THE PERIODIC EFFICIENCY TEST</p>	<p>The batteries of the UPS should be replaced in that they are no longer able to maintain the charge for a sufficient time to ensure the required autonomy. Warning: The batteries are to be replaced by qualified staff</p>
<p>THE DISPLAY SHOWS ONE OR MORE OF THE FOLLOWING CODES: F34, F35, F36, L34, L35, L36</p>	<ul style="list-style-type: none"> ▪ AMBIENT TEMPERATURE OVER 40°C ▪ HEAT SOURCES CLOSE TO THE UPS ▪ VENTILATION SLITS OBSTRUCTED OR TOO CLOSE TO WALLS 	<p>Activate the maintenance bypass (SWMB) without powering off the UPS; in this way, the fans cool the heat sink more quickly. Eliminate the cause of the overtemperature and wait for the temperature of the heat sink to drop. Exclude the maintenance bypass.</p>
	<p>FAULT IN TEMPERATURE PROBE OR UPS COOLING SYSTEM</p>	<p>Insert the maintenance bypass (SWMB) without turning off the UPS so that the fans, continuing to run, cool the heat sink more quickly and wait for the temperature of the heat sink to drop. Turn the UPS off and then on again. Exclude the maintenance bypass. If the problem persists, call your local service centre</p>
<p>THE DISPLAY SHOWS ONE OR MORE OF THE FOLLOWING CODES: F37, L37</p>	<ul style="list-style-type: none"> ▪ AMBIENT TEMPERATURE IS OVER 40°C ▪ HEAT SOURCES CLOSE TO THE UPS ▪ VENTILATION SLITS OBSTRUCTED OR TOO CLOSE TO WALLS ▪ FAULT IN THE TEMPERATURE PROBE OR BATTERY CHARGER COOLING SYSTEM 	<p>Eliminate the cause of the overtemperature. Open the battery fuse holder isolators (SWBATT) and wait for the temperature of the battery charger heat sink to drop. Close the battery fuse holders. If the problem recurs, call your local service centre. WARNING: never open the SWBATT fuse holders during battery operation.</p>
<p>THE DISPLAY SHOWS ONE OR MORE OF THE FOLLOWING CODES: L11, L12, L13</p>	<p>BREAKDOWN OR MALFUNCTIONING OF THE STATIC BYPASS</p>	<p>Activate the maintenance bypass (SWMB), switch the UPS off and then on again. Exclude the maintenance bypass. If the fault persists, contact the nearest technical support centre</p>
<p>THE DISPLAY SHOWS NOTHING OR PROVIDES INCORRECT INFORMATION</p>	<p>THE DISPLAY HAS POWER SUPPLY PROBLEMS</p>	<p>Close Manual Bypass (SWMB) keeping closed INPUT and OUTPUT switches. Open input switch (SWIN and SWBYP) and wait until UPS is completely turned OFF. Turn ON SWIN and SWBYP again and verify display regular operation. Exclude the maintenance bypass. If the fault persists, contact the nearest technical support centre.</p>
<p>THE DISPLAY IS OFF, THE FANS ARE OFF BUT THE LOAD IS POWERED</p>	<p>DUE TO A FAULT IN THE AUXILIARIES, THE UPS IS IN BYPASS SUPPORTED BY THE REDUNDANT POWER SUPPLY</p>	<p>Activate the maintenance bypass (SWMB), shut down the UPS completely and wait for a few seconds. Try to switch on again. If the display does not light up or the sequence fails, contact the nearest technical support centre and leave the UPS in manual bypass mode.</p>

STATUS / ALARM CODES

Using a sophisticated self-diagnostic system, the UPS can check and indicate on the display panel its status and any errors and/or faults that have occurred during its operation. When a problem arises, the UPS signals the event by showing the code and corresponding type of alarm on the display.

- **Status:** indicates the current status of the UPS.

CODE	DESCRIPTION
S01	Precharging
S02	Load not powered (stand-by status)
S03	Power-on phase
S04	Load powered by bypass line
S05	Load powered by inverter
S06	Battery operation
S07	Waiting for batteries to recharge
S08	Economy mode enabled
S09	Ready for power on
S10	UPS locked – load not powered
S11	UPS locked – load on bypass
S12	BOOST stage or battery-charger locked – load not powered
S13	Frequency converter - load powered by inverter

- **Command:** indicates that a command has been activated.

CODE	DESCRIPTION
C01	Remote power-off command
C02	Remote load on bypass command
C03	Remote power-on command
C04	Battery test running
C05	Manual bypass command
C06	Emergency power-off command
C07	Remote battery charger power-off command
C08	Load on bypass command

- **Warning:** messages that refer to a specific configuration or operation of the UPS.

CODE	DESCRIPTION
W01	Battery low warning
W02	Programmed power-off enabled
W03	Programmed power-off command imminent
W04	Bypass disabled
W05	Synchronization disabled (UPS in Free running mode)

- **Anomaly:** “minor” problems that do not bring the UPS to a halt but affect its performance or inhibit the use of some of its functions.

CODE	DESCRIPTION
A03	Inverter Desynchronized
A04	External synchronism failed
A05	Overvoltage on input line of Phase1
A06	Overvoltage on input line of Phase2
A07	Overvoltage on input line of Phase3
A08	Undervoltage on input line of Phase1
A09	Undervoltage on input line of Phase2
A10	Undervoltage on input line of Phase3
A11	Input frequency outside tolerance limits
A13	Voltage on bypass line of Phase1 outside tolerance limits
A14	Voltage on bypass line of Phase2 outside tolerance limits
A15	Voltage on bypass line of Phase3 outside tolerance limits
A16	Bypass frequency outside tolerance limits
A18	Voltage on bypass line out of range
A19	Overcurrent peak on output Phase 1
A20	Overcurrent peak on output Phase2
A21	Overcurrent peak on output Phase 3
A22	Load on Phase1 > user-defined threshold
A23	Load on Phase2 > user-defined threshold
A24	Load on Phase3 > user-defined threshold
A25	Output isolator open
A26	Positive branch batteries missing or battery fuses open
A27	Negative branch batteries missing or battery fuses open
A29	System temperature probe faulty
A30	System temperature < 0°C
A31	System temperature too high
A32	Temperature of heat sink 1 < 0°C
A33	Temperature of heat sink 2 < 0°C
A34	Temperature of heat sink 3 < 0°C
A35	Internal battery temperature probe faulty
A36	Internal battery overtemperature
A37	External battery temperature probe faulty
A38	External battery overtemperature
A39	Positive branch batteries to be replaced
A40	Negative branch batteries to be replaced

➤ **Fault:** more critical problems than “Anomalies” in that, if they persist, they may bring the UPS to a halt.

CODE	DESCRIPTION
F01	Internal communication error
F02	Incorrect input phase direction.
F03	Input fuse of Phase1 broken or input relay blocked (will not close)
F04	Input fuse of Phase 2 broken or input relay blocked (will not close)
F05	Input fuse of Phase3 broken or input relay blocked (will not close)
F06	Input relay of Phase1 blocked (always closed)
F07	Input relay of Phase2 blocked (always closed)
F08	Input relay of Phase3 blocked (always closed)
F09	Precharge of positive branch capacitors failed
F10	Precharge of negative branch capacitors failed
F11	BOOST stage anomaly
F12	Incorrect bypass phase direction.
F14	Sine wave of inverter phase1 distorted
F15	Sine wave of inverter phase2 distorted
F16	Sine wave of inverter phase3 distorted
F17	Inverter stage anomaly
F19	Positive battery overvoltage
F20	Negative battery overvoltage
F21	Positive battery undervoltage
F22	Negative battery undervoltage
F23	Overload at output
F26	Output relay of Phase1 blocked
F27	Output relay of Phase2 blocked
F28	Output relay of Phase3 blocked
F29	Output fuse of Phase1 blown
F30	Output fuse of Phase2 blown
F31	Output fuse of Phase3 blown
F32	Battery charger stage anomaly
F33	Output fuse of battery charger blown
F34	Heat sink overtemperature
F37	Battery charger overtemperature
F42	BOOST battery 1 fuse blown
F43	BOOST battery 2 fuse blown
F44	BOOST battery 3 fuse blown

- **Lock:** indicate a breakdown of the UPS or one of its parts. Locks are normally preceded by an alarm signal. In the event of a fault and resultant breakdown of the inverter, the inverter will be switched off and the load will be powered by the bypass line (this procedure is excluded for breakdowns caused by high and persistent overloads and by short circuits).

CODE	DESCRIPTION
L01	Incorrect auxiliary power supply
L02	One or more internal cables disconnected
L03	Phase 1 input fuse broken or input relay locked (will not close)
L04	Phase 2 input fuse broken or input relay locked (will not close)
L05	Phase 3 input fuse broken or input relay locked (will not close)
L06	BOOST stage overvoltage positive
L07	BOOST stage overvoltage negative
L08	BOOST stage undervoltage positive
L09	BOOST stage undervoltage negative
L10	Static bypass switch fault
L11	L1 bypass output breakdown
L12	L2 bypass output breakdown
L13	L3 bypass output breakdown
L14	Phase1 inverter overvoltage
L15	Phase2 inverter overvoltage
L16	Phase3 inverter overvoltage
L17	Phase1 inverter undervoltage
L18	Phase2 inverter undervoltage
L19	Phase3 inverter undervoltage
L20	Direct voltage at output of inverter or Sine wave of Phase1 inverter distorted
L21	Direct voltage at output of inverter or Sine wave of Phase2 inverter distorted
L22	Direct voltage at output of inverter or Sine wave of Phase3 inverter distorted
L23	Overload at output of Phase1
L24	Overload at output of Phase2
L25	Overload at output of Phase3
L26	Short circuit at output of Phase1
L27	Short circuit at output of Phase2
L28	Short circuit at output of Phase3
L29	Phase 1 output fuse broken or output relay locked (will not close)
L30	Phase 2 output fuse broken or output relay locked (will not close)
L31	Phase 3 output fuse broken or output relay locked (will not close)
L34	Heat sink Phase 1 overtemperature
L35	Heat sink Phase 2 overtemperature
L36	Heat sink Phase 3 overtemperature
L37	Battery charger overtemperature
L38	Temperature probe of heat sink Phase 1 faulty
L39	Temperature probe of heat sink Phase 2 faulty
L40	Temperature probe of heat sink Phase 3 faulty
L41	Temperature probe of battery charger faulty
L42	BOOST battery 1 fuse blown
L43	BOOST battery 2 fuse blown
L44	BOOST battery 3 fuse blown

TECHNICAL DATA

UPS Models	10 kVA	12 kVA	15 kVA	20 kVA
------------	--------	--------	--------	--------

Input stage

Rated voltage	380-400-415 Vac Three-phase with neutral (4 wires)			
Rated frequency	50-60Hz			
Accepted tolerance for input voltage without activation of battery (for 400Vac)	±20% @ 100% load -40% +20% @50% load			
Accepted tolerance for input frequency without activation of battery (for 50/60Hz)	±20% 40-72Hz			
Technology	IGBT high frequency with PFC control, independent digital average current mode on each input phase			
Input current harmonic distortion	THDi ≤ 3 % ⁽⁷⁾			
Input power factor	≥0.99			
Power Walk-in	Programmable from 1 to 125 sec. in steps of 1 sec.			

Output stage

Rated voltage ⁽¹⁾	380/400/415 Vac Three-phase with neutral (4 wires)			
Rated frequency ⁽²⁾	50/60Hz			
Rated apparent output power	10kVA	12kVA	15kVA	20kVA
Rated active output power	9kW	10.8kW	13.5kW	18kW
Output power factor	0,9			
Short circuit current	1,5x In for t>500ms			
Precision of output voltage (with respect to output voltage 400Vac)	± 1%			
Static stability ⁽³⁾	± 0.5%			
Dynamic stability	± 3% resistive load ⁽⁴⁾			
Output voltage harmonic distortion with standardized linear and distorting load	≤1% with linear load ≤3% with distorting load			
Crest factor allowed at rated load	3:1			
Precision of frequency in free running mode	0.01%			
Inverter overload (Vin>345V AC)	103% Infinite, 110% 10 min, 125% 1 min			
Bypass Overload	110% Infinite, 125% 60 minutes, 150% 10 minutes			
Technology	IGBT high frequency with multiprocessor digital control (DSP+μP), voltage/current based on signal processing methods with feed forward			

Battery charger stage

Rated voltage	±240Vdc			
Maximum recharging current ⁽⁵⁾	6A			
Battery charger algorithm	Two levels with temperature compensation			
Technology	Analogue switching current mode under the control of the μP (PWM regulation of charging voltage and current)			
Tolerance of input voltage for recharging at maximum current	345-480Vac			

UPS Models	10 kVA	12 kVA	15 kVA	20 kVA
------------	--------	--------	--------	--------

Dimensions and weight

W x D x H	MCT	320 x 840 x 930 mm			
	MST	440 x 850 x 1320 mm			
Weight without batteries	MCT	80 Kg	82 Kg	90 Kg	95 Kg
	MST	105 Kg	110 Kg	115 Kg	120 Kg
Weight with batteries	MCT	185 Kg	187 Kg	195 Kg	200 Kg
	MST	315 Kg	320 Kg	325 Kg	330 Kg

Modes and efficiency values

Operating modes	True on line double conversion ECO mode Smart Active mode Stand-by Off (Emergency) Frequency Converter			
AC/AC efficiency in on line mode	≥93.5%		≥94%	
AC/AC efficiency in Eco mode	≥98%			
DC/AC efficiency in autonomy mode	≥92.5%		≥93.5%	

Miscellaneous

Noise	≤48dB(A)	≤52dB(A)
Color	RAL 7016	
Ambient temperature ⁽⁶⁾	0 – 40 °C	

- (1) To maintain the output voltage within the range of precision indicated, it may have to be recalibrated after a long period of operation
- (2) If the mains frequency is within $\pm 5\%$ of the selected value, the UPS is synchronized with the mains. If the frequency is outside the tolerance limits or running on the battery, the frequency is the value selected $\pm 0.1\%$
- (3) Mains/Battery @ load 0% -100%
- (4) @ Mains / battery / mains @ resistive load 0% / 100% / 0%
- (5) The recharging current is regulated automatically according to the capacity of the battery installed
- (6) 20 – 25 °C for maximum battery life
- (7) @ 100% load & THDv $\leq 1\%$

Battery Box	BBX 1320 480V BB NP T4 3F	BBX 1320 480V BB NP T2 3F	BBX 1320 480V BB NP T5 3F
-------------	------------------------------	------------------------------	------------------------------

Battery

Rated voltage per branch	240 Vdc		
No. batteries / V / Ah	80 / 12 / 9	120 / 12 / 7	120 / 12 / 9

Miscellaneous

Ambient temperature ⁽¹⁾	0 – 40 °C		
Humidity	<95% non-condensing		
Protective devices	Overcurrent – Short circuit		
W x D x H	400 x 815 x 1320 mm		
Weight	300 Kg	390 Kg	400 Kg

- (1) 20 – 25 °C for maximum battery life



www.riello-ups.com

RPS SpA – *Riello Power Solutions*
Viale Europa, 7
37045 Legnago (VR)
Italy

0MNMSTK10RU5LUC